



Cisco Nexus 93180YC-FX NX-OS Mode Switch Hardware Installation Guide

First Published: 2017-08-25

Last Modified: 2020-07-22

Americas Headquarters

Cisco Systems, Inc.
170 West Tasman Drive
San Jose, CA 95134-1706
USA
<http://www.cisco.com>
Tel: 408 526-4000
800 553-NETS (6387)
Fax: 408 527-0883

THE SPECIFICATIONS AND INFORMATION REGARDING THE PRODUCTS IN THIS MANUAL ARE SUBJECT TO CHANGE WITHOUT NOTICE. ALL STATEMENTS, INFORMATION, AND RECOMMENDATIONS IN THIS MANUAL ARE BELIEVED TO BE ACCURATE BUT ARE PRESENTED WITHOUT WARRANTY OF ANY KIND, EXPRESS OR IMPLIED. USERS MUST TAKE FULL RESPONSIBILITY FOR THEIR APPLICATION OF ANY PRODUCTS.

THE SOFTWARE LICENSE AND LIMITED WARRANTY FOR THE ACCOMPANYING PRODUCT ARE SET FORTH IN THE INFORMATION PACKET THAT SHIPPED WITH THE PRODUCT AND ARE INCORPORATED HEREIN BY THIS REFERENCE. IF YOU ARE UNABLE TO LOCATE THE SOFTWARE LICENSE OR LIMITED WARRANTY, CONTACT YOUR CISCO REPRESENTATIVE FOR A COPY.

The following information is for FCC compliance of Class A devices: This equipment has been tested and found to comply with the limits for a Class A digital device, pursuant to part 15 of the FCC rules. These limits are designed to provide reasonable protection against harmful interference when the equipment is operated in a commercial environment. This equipment generates, uses, and can radiate radio-frequency energy and, if not installed and used in accordance with the instruction manual, may cause harmful interference to radio communications. Operation of this equipment in a residential area is likely to cause harmful interference, in which case users will be required to correct the interference at their own expense.

The following information is for FCC compliance of Class B devices: This equipment has been tested and found to comply with the limits for a Class B digital device, pursuant to part 15 of the FCC rules. These limits are designed to provide reasonable protection against harmful interference in a residential installation. This equipment generates, uses and can radiate radio frequency energy and, if not installed and used in accordance with the instructions, may cause harmful interference to radio communications. However, there is no guarantee that interference will not occur in a particular installation. If the equipment causes interference to radio or television reception, which can be determined by turning the equipment off and on, users are encouraged to try to correct the interference by using one or more of the following measures:

- Reorient or relocate the receiving antenna.
- Increase the separation between the equipment and receiver.
- Connect the equipment into an outlet on a circuit different from that to which the receiver is connected.
- Consult the dealer or an experienced radio/TV technician for help.

Modifications to this product not authorized by Cisco could void the FCC approval and negate your authority to operate the product.

The Cisco implementation of TCP header compression is an adaptation of a program developed by the University of California, Berkeley (UCB) as part of UCB's public domain version of the UNIX operating system. All rights reserved. Copyright © 1981, Regents of the University of California.

NOTWITHSTANDING ANY OTHER WARRANTY HEREIN, ALL DOCUMENT FILES AND SOFTWARE OF THESE SUPPLIERS ARE PROVIDED "AS IS" WITH ALL FAULTS. CISCO AND THE ABOVE-NAMED SUPPLIERS DISCLAIM ALL WARRANTIES, EXPRESSED OR IMPLIED, INCLUDING, WITHOUT LIMITATION, THOSE OF MERCHANTABILITY, FITNESS FOR A PARTICULAR PURPOSE AND NONINFRINGEMENT OR ARISING FROM A COURSE OF DEALING, USAGE, OR TRADE PRACTICE.

IN NO EVENT SHALL CISCO OR ITS SUPPLIERS BE LIABLE FOR ANY INDIRECT, SPECIAL, CONSEQUENTIAL, OR INCIDENTAL DAMAGES, INCLUDING, WITHOUT LIMITATION, LOST PROFITS OR LOSS OR DAMAGE TO DATA ARISING OUT OF THE USE OR INABILITY TO USE THIS MANUAL, EVEN IF CISCO OR ITS SUPPLIERS HAVE BEEN ADVISED OF THE POSSIBILITY OF SUCH DAMAGES.

Any Internet Protocol (IP) addresses and phone numbers used in this document are not intended to be actual addresses and phone numbers. Any examples, command display output, network topology diagrams, and other figures included in the document are shown for illustrative purposes only. Any use of actual IP addresses or phone numbers in illustrative content is unintentional and coincidental.

All printed copies and duplicate soft copies of this document are considered uncontrolled. See the current online version for the latest version.

Cisco has more than 200 offices worldwide. Addresses and phone numbers are listed on the Cisco website at www.cisco.com/go/offices.

The documentation set for this product strives to use bias-free language. For purposes of this documentation set, bias-free is defined as language that does not imply discrimination based on age, disability, gender, racial identity, ethnic identity, sexual orientation, socioeconomic status, and intersectionality. Exceptions may be present in the documentation due to language that is hardcoded in the user interfaces of the product software, language used based on standards documentation, or language that is used by a referenced third-party product.

Cisco and the Cisco logo are trademarks or registered trademarks of Cisco and/or its affiliates in the U.S. and other countries. To view a list of Cisco trademarks, go to this URL: <https://www.cisco.com/c/en/us/about/legal/trademarks.html>. Third-party trademarks mentioned are the property of their respective owners. The use of the word partner does not imply a partnership relationship between Cisco and any other company. (1721R)

© 2017 Cisco Systems, Inc. All rights reserved.



CONTENTS

PREFACE

Preface	vii
Audience	vii
Documentation Conventions	vii
Related Documentation for Cisco Nexus 9000 Series NX-OS Software	viii
Documentation Feedback	x
Communications, Services, and Additional Information	x

CHAPTER 1

Overview	1
Overview	1

CHAPTER 2

Preparing the Site	5
Temperature Requirements	5
Humidity Requirements	5
Altitude Requirements	6
Dust and Particulate Requirements	6
Minimizing Electromagnetic and Radio Frequency Interference	6
Shock and Vibration Requirements	7
Grounding Requirements	7
Planning for Power Requirements	7
Airflow Requirements	9
Rack and Cabinet Requirements	9
Clearance Requirements	10

CHAPTER 3

Installing the Switch Chassis	13
Safety	13
Installation Options with Rack-Mount Kits	16

Airflow Considerations	17
Installation Guidelines	17
Unpacking and Inspecting the Switch	18
Installing the Switch Using the NXX-ACC-KIT-1RU Rack-Mount Kit	19
Installing the Switch Using the N3K-C3064-ACC-KIT Rack-Mount Kit	23
Installing the Airflow Sleeve (N9K-AIRFLOW-SLV)	27
Grounding the Chassis	29
Starting the Switch	30

CHAPTER 4	Connecting the Switch to the Network	33
	Overview of Network Connections	33
	Connecting a Console to the Switch	34
	Creating the Initial Switch Configuration	35
	Setting Up the Management Interface	36
	Connecting Interface Ports to Other Devices	37
	Uplink Connections	37
	Downlink Connections	37

CHAPTER 5	Replacing Components	39
	Replacing a Fan Module	39
	Removing a Fan Module	39
	Installing a Fan Module	40
	Replacing a Power Supply Module	40
	Replacing an AC Power Supply	40
	Replacing a High Voltage (HVAC/HVDC) Power Supply	41
	Replacing a DC Power Supply	43

APPENDIX A	Rack Specifications	45
	Overview of Racks	45
	General Requirements for Cabinets and Racks	45
	Requirements Specific to Standard Open Racks	46
	Requirements Specific to Perforated Cabinets	46
	Cable Management Guidelines	47

APPENDIX B	System Specifications	49
	Environmental Specifications	49
	Switch Dimensions	49
	Switch and Module Weights and Quantities	50
	Transceiver and Cable Specifications	50
	Switch Power Input Requirements	50
	Power Specifications	51
	500-W AC Power Supply Specifications	51
	1200-W HVAC/HVDC Power Supply Specifications	51
	930-W DC Power Supply Specifications	52
	Power Cable Specifications	53
	Power Cable Specifications for AC Power Supplies	53
	HVAC/HVDC Power Cables Supported by ACI-Mode and NX-OS Mode Switches	54
	DC Power Cable Specifications	55
	Regulatory Standards Compliance Specifications	55

APPENDIX C	LEDs	57
	Switch Chassis LEDs	57
	Fan Module LEDs	57
	Power Supply LEDs	57

APPENDIX D	Additional Kits	59
	Rack Mount Kit NXK-ACC-KIT-1RU	59
	Rack Mount Kit N3K-C3064-ACC-KIT	60
	Airflow Sleeve	60

APPENDIX E	Site Preparation and Maintenance Records	63
	Site Preparation Checklist	63
	Contact and Site Information	64
	Chassis and Module Information	65



Preface

This preface includes the following sections:

- [Audience, on page vii](#)
- [Documentation Conventions, on page vii](#)
- [Related Documentation for Cisco Nexus 9000 Series NX-OS Software, on page viii](#)
- [Documentation Feedback, on page x](#)
- [Communications, Services, and Additional Information, on page x](#)

Audience

This publication is for network administrators who install, configure, and maintain Cisco Nexus switches.

Documentation Conventions

Command descriptions use the following conventions:

Convention	Description
bold	Bold text indicates the commands and keywords that you enter literally as shown.
<i>Italic</i>	Italic text indicates arguments for which the user supplies the values.
[x]	Square brackets enclose an optional element (keyword or argument).
[x y]	Square brackets enclosing keywords or arguments separated by a vertical bar indicate an optional choice.
{x y}	Braces enclosing keywords or arguments separated by a vertical bar indicate a required choice.
[x {y z}]	Nested set of square brackets or braces indicate optional or required choices within optional or required elements. Braces and a vertical bar within square brackets indicate a required choice within an optional element.

Convention	Description
<i>variable</i>	Indicates a variable for which you supply values, in context where italics cannot be used.
string	A nonquoted set of characters. Do not use quotation marks around the string or the string will include the quotation marks.

Examples use the following conventions:

Convention	Description
screen font	Terminal sessions and information the switch displays are in screen font.
boldface screen font	Information you must enter is in boldface screen font.
<i>italic screen font</i>	Arguments for which you supply values are in italic screen font.
<>	Nonprinting characters, such as passwords, are in angle brackets.
[]	Default responses to system prompts are in square brackets.
!,#	An exclamation point (!) or a pound sign (#) at the beginning of a line of code indicates a comment line.

Related Documentation for Cisco Nexus 9000 Series NX-OS Software

The entire Cisco NX-OS 9000 Series documentation set is available at the following URL:

https://www.cisco.com/en/US/products/ps13386/tsd_products_support_series_home.html

Release Notes

The release notes are available at the following URL:

https://www.cisco.com/en/US/products/ps13386/prod_release_notes_list.html

Configuration Guides

These guides are available at the following URL:

https://www.cisco.com/en/US/products/ps13386/products_installation_and_configuration_guides_list.html

The documents in this category include:

- *Cisco Nexus 2000 Series NX-OS Fabric Extender Software Configuration Guide for Cisco Nexus 9000 Series Switches*
- *Cisco Nexus 9000 Series NX-OS Fundamentals Configuration Guide*
- *Cisco Nexus 9000 Series NX-OS High Availability and Redundancy Guide*
- *Cisco Nexus 9000 Series NX-OS Interfaces Configuration Guide*
- *Cisco Nexus 9000 Series NX-OS Layer 2 Switching Configuration Guide*

- *Cisco Nexus 9000 Series NX-OS Multicast Routing Configuration Guide*
- *Cisco Nexus 9000 Series NX-OS Quality of Service Configuration Guide*
- *Cisco Nexus 9000 Series NX-OS Security Configuration Guide*
- *Cisco Nexus 9000 Series NX-OS System Management Configuration Guide*
- *Cisco Nexus 9000 Series NX-OS Unicast Routing Configuration Guide*
- *Cisco Nexus 9000 Series NX-OS Verified Scalability Guide*
- *Cisco Nexus 9000 Series NX-OS VXLAN Configuration Guide*

Other Software Documents

- *Cisco Nexus 7000 Series and 9000 Series NX-OS MIB Quick Reference*
- *Cisco Nexus 9000 Series NX-OS Programmability Guide*
- *Cisco Nexus 9000 Series NX-OS Software Upgrade and Downgrade Guide*
- *Cisco Nexus 9000 Series NX-OS System Messages Reference*
- *Cisco Nexus 9000 Series NX-OS Troubleshooting Guide*
- *Cisco NX-OS Licensing Guide*
- *Cisco NX-OS XML Interface User Guide*

Hardware Documents

- *Cisco Nexus 3000 Series Hardware Installation Guide*
- *Cisco Nexus 92160YC-X NX-OS Mode Switch Hardware Installation Guide*
- *Cisco Nexus 92300YC NX-OS Mode Switch Hardware Installation Guide*
- *Cisco Nexus 92304QC NX-OS Mode Switch Hardware Installation Guide*
- *Cisco Nexus 9236C NX-OS Mode Switch Hardware Installation Guide*
- *Cisco Nexus 9272Q NX-OS Mode Switch Hardware Installation Guide*
- *Cisco Nexus 93108TC-EX NX-OS Mode Switch Hardware Installation Guide*
- *Cisco Nexus 93108TC-FX NX-OS Mode Switch Hardware Installation Guide*
- *Cisco Nexus 93120TX NX-OS Mode Switch Hardware Installation Guide*
- *Cisco Nexus 93128TX NX-OS Mode Switch Hardware Installation Guide*
- *Cisco Nexus 93180LC-EX NX-OS Mode Switch Hardware Installation Guide*
- *Cisco Nexus 93180YC-EX NX-OS Mode Switch Hardware Installation Guide*
- *Cisco Nexus 93180YC-FX NX-OS Mode Switch Hardware Installation Guide*
- *Cisco Nexus 9332PQ NX-OS-Mode Switch Hardware Installation Guide*

- *Cisco Nexus 9348GC-FXP NX-OS Mode Switch Hardware Installation Guide*
- *Cisco Nexus 9372PX and 9372PX-E NX-OS Mode Switches Hardware Installation Guide*
- *Cisco Nexus 9372TX and 9372TX-E NX-OS Mode Switches Hardware Installation Guide*
- *Cisco Nexus 9396PX NX-OS Mode Switch Hardware Installation Guide*
- *Cisco Nexus 9396TX NX-OS Mode Switch Hardware Installation Guide*
- *Cisco Nexus 9504 NX-OS Mode Switch Hardware Installation Guide*
- *Cisco Nexus 9508 NX-OS Mode Switch Hardware Installation Guide*
- *Cisco Nexus 9516 NX-OS Mode Switch Hardware Installation Guide*
- *Regulatory, Compliance, and Safety Information for the Cisco Nexus 3000 and 9000 Series*

Documentation Feedback

To provide technical feedback on this document, or to report an error or omission, please send your comments to nexus9k-docfeedback@cisco.com. We appreciate your feedback.

Communications, Services, and Additional Information

- To receive timely, relevant information from Cisco, sign up at [Cisco Profile Manager](#).
- To get the business impact you're looking for with the technologies that matter, visit [Cisco Services](#).
- To submit a service request, visit [Cisco Support](#).
- To discover and browse secure, validated enterprise-class apps, products, solutions and services, visit [Cisco Marketplace](#).
- To obtain general networking, training, and certification titles, visit [Cisco Press](#).
- To find warranty information for a specific product or product family, access [Cisco Warranty Finder](#).

Cisco Bug Search Tool

[Cisco Bug Search Tool](#) (BST) is a web-based tool that acts as a gateway to the Cisco bug tracking system that maintains a comprehensive list of defects and vulnerabilities in Cisco products and software. BST provides you with detailed defect information about your products and software.



CHAPTER 1

Overview

- [Overview, on page 1](#)

Overview

The Cisco Nexus 93180YC-FX switch (N9K-C93180YC-FX) is a 1-RU, fixed-port switch designed for Top-of-Rack (TOR), Middle-of-Rack (MoR), and End-of-Rack (EoR) deployment in data centers. This switch has 48 10/25-Gigabit SFP+ downlink ports that support 1-Gigabit, 10-Gigabit, and 25-Gigabit Ethernet connections and 8-, 16-, and 32-Gigabit Fibre Channel connections, and it has six fixed 40/100-Gigabit QSFP28 uplink ports that support combinations of 10-, 25-, 40-, 50-, and 100-Gigabit connectivity. You can set the downlink port speeds on a port-by-port basis. The chassis for this switch includes the following user-replaceable components:

- Fan modules (four) with the following airflow choices:
 - Port-side intake airflow with burgundy coloring (NXA-FAN-30CFM-B)
 - Port-side exhaust airflow with blue coloring (NXA-FAN-30CFM-F)



Note The port-side intake airflow fan module with burgundy coloring can go from 0 to 55 degrees Celsius.



Note *Table 1: Fan Speeds for This Switch*

	Port-Side Intake Fan Speed %	Port-Side Exhaust Fan Speed %
Typical/Minimum	50%	70%
Maximum	100%	100%



Note Each fan module has two rotors. The switch can function normally if one rotor inside the any one fan module fails. In case of more than one rotor failure, the switch will issue a warning and power down in 2 minute.

- Power supply modules (two—one for operations and one for redundancy [1+1]) with the following choices:
 - 500-W AC power supply with port-side exhaust airflow (blue coloring) (NXA-PAC-500W-PE)
 - 500-W AC power supply with port-side intake airflow (burgundy coloring) (NXA-PAC-500W-PI)
 - 1200-W HVAC/HVDC power supply with dual-direction airflow (white coloring) (N9K-PUV-1200W)
 - 930-W DC power supply with port-side exhaust airflow (blue coloring) (NXA-PDC-930W-PE)
 - 930-W DC power supply with port-side intake airflow (burgundy coloring) (NXA-PDC-930W-PI)



Note Both power supplies must be the same type of power source. Do not mix AC and DC power sources.



Note All fan modules and power supplies must use the same airflow direction during operations. If you are using the 1200-W HVAC/HVDC power supply, the power supply automatically uses the same airflow direction as used by the other modules in the switch.

Deployment Scheme for SFP-10G-T-X Transceivers

The following figure shows the maximum configuration density of SFP-10G-T-X SFP+ transceivers for this switch.

1	3	5	7	9	11	13	15	17	19	21	23	25	27	29	31	33	35	37	39	41	43	45	47	49	51	53
2	4	6	8	10	12	14	16	18	20	22	24	26	28	30	32	34	36	38	40	42	44	46	48	50	52	54

503038



Active Port deploying the SFP+ 10GBASE-T transceiver, with max power consumption up to 2.5W.

Once configured with “media-type 10g-tx” in NX-OS or “Link Level Policy -> Physical Media Type -> SFP 10G TX” in ACI, these ports can deploy SFP-10G-T-X. Without such configuration, they behave like normal ports.

	<p>Port Shutdown or Active with Passive Copper Cables only (Max. power consumption up to 0.1W).</p> <p>Once 10g-tx is configured on yellow ports, ports to the left, right, top and bottom of the yellow port are referenced as blue ports. These adjacent ports will then support only low power Passive Copper DAC cable, or these can be left empty to conserve power. If 10g-tx configuration is removed from adjacent yellow ports, the blue ports will revert to behaving like normal ports.</p>
	<p>Active Port deploying any Cisco 1/10/25G optics (SFP, SFP+, SFP28) EXCLUDING SFP+ 10GBASE-T, with max power consumption up to 1.5W. These ports are not part of any scheme and can deploy all regular Cisco optics and behave like normal ports.</p>

The following figure shows the hardware features seen from the port side of the chassis.

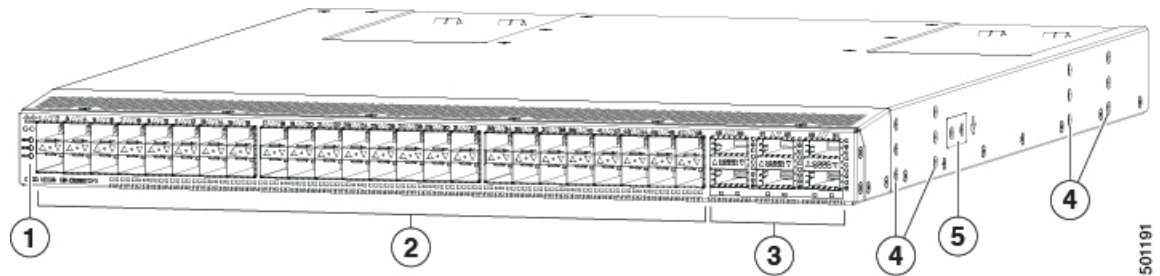

1	Chassis LEDs (Beacon [BCN], Status [STS], and Environment [ENV])	4	Screw holes (6) for attaching rack mounting brackets.
2	48 10/25-Gigabit SFP28 ports to	5	Screw holes (2) for attaching grounding lug.
3	6 40/100-Gigabit QSFP28 optical ports for uplink connections to		

To determine which transceivers, adapters, and cables this switch supports, see the [Cisco Transceiver Modules Compatibility Information](#) document.

The following figure shows the hardware features seen from the power supply side of the chassis.

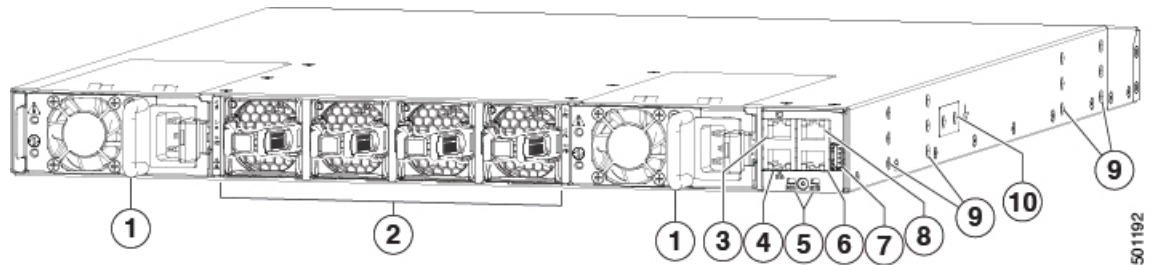

1	Two power supplies (one used for operations and one used for redundancy) (AC power supplies shown) with power supply slot 1 on the left and slot 2 on the right.	6	Console port (RS232 port)
2	Four fan modules with fan slot 1 on the left and fan slot 4 on the right	7	USB port used for saving or copying functions

3	L1 (software defined port)	8	Out-of-band management port (RJ-45 port)
4	L2 (software defined port)	9	Screw holes (6) for attaching rack mounting brackets
5	Chassis LEDs (Beacon [BCN] and Status [STS])	10	Screw holes (2) for attaching grounding lug.



Note There is a limit to USB 2.0 devices that use less than 2.5 W (less than 0.5 A inclusive of surge current). There is no support for devices, such as external hard drives, that instantaneously draw more than 0.5 A.

Depending on whether you plan to position the ports in a hot or cold aisle, you can order the fan and power supply modules with port-side intake or port-side exhaust airflow. To determine the airflow direction of the modules installed in your switch, see the following table.

Replaceable Modules	Port-Side Intake Airflow Coloring	Port-Side Exhaust Airflow Coloring
Fans	Burgundy	Blue
AC power supplies	Burgundy	Blue
HVAC/HVDC power supplies	White	
DC power supplies	Burgundy	Blue

The fan and power supply modules are field replaceable and you can replace one fan module or one power supply module during operations so long as the other modules are operating. If you have only one power supply that is installed, you can install the replacement power supply in the open slot before removing the original power supply.



Note Fans and power supply modules must have the same direction of airflow. Otherwise, the switch can overheat and shut down. If you are installing a dual-direction power supply, that module will automatically use the same airflow direction as the other modules in the switch.



Caution If the switch has port-side intake airflow (burgundy coloring for fan modules), you must locate the ports in the cold aisle. If the switch has port-side exhaust airflow (blue coloring for fan modules), you must locate the ports in the hot aisle. If you locate the air intake in a hot aisle, the switch can overheat and shut down.



CHAPTER 2

Preparing the Site

- [Temperature Requirements, on page 5](#)
- [Humidity Requirements, on page 5](#)
- [Altitude Requirements, on page 6](#)
- [Dust and Particulate Requirements, on page 6](#)
- [Minimizing Electromagnetic and Radio Frequency Interference, on page 6](#)
- [Shock and Vibration Requirements, on page 7](#)
- [Grounding Requirements, on page 7](#)
- [Planning for Power Requirements, on page 7](#)
- [Airflow Requirements, on page 9](#)
- [Rack and Cabinet Requirements, on page 9](#)
- [Clearance Requirements, on page 10](#)

Temperature Requirements

The switch requires an operating temperature of 32 to 104 degrees Fahrenheit (0 to 40 degrees Celsius). If the switch is not operating, the temperature must be between –40 to 158 degrees Fahrenheit (–40 to 70 degrees Celsius).

Humidity Requirements

High humidity can cause moisture to enter the switch. Moisture can cause corrosion of internal components and degradation of properties such as electrical resistance, thermal conductivity, physical strength, and size. The switch is rated to withstand from 5- to 95-percent (nonoperating) and 5- to 90-percent (operating) relative humidity.

Buildings in which the climate is controlled by air-conditioning in the warmer months and by heat during the colder months usually maintain an acceptable level of humidity for the switch equipment. However, if the switch is located in an unusually humid location, use a dehumidifier to maintain the humidity within an acceptable range.

Altitude Requirements

Altitude rating is based on power supply installed; see critical components list in the system CB report for altitude rating.

Dust and Particulate Requirements

Exhaust fans cool power supplies and system fans cool switches by drawing in air and exhausting air out through various openings in the chassis. However, fans also ingest dust and other particles, causing contaminant buildup in the switch and increased internal chassis temperature. Dust and particles can act as insulators and interfere with the mechanical components in the switch. A clean operating environment can greatly reduce the negative effects of dust and other particles.

In addition to keeping your environment free of dust and particles, follow these precautions to avoid contamination of your switch:

- Do not permit smoking near the switch.
- Do not permit food or drink near the switch.

Minimizing Electromagnetic and Radio Frequency Interference

Electromagnetic interference (EMI) and radio frequency interference (RFI) from the switch can adversely affect other devices, such as radio and television (TV) receivers. Radio frequencies that emanate from the switch can also interfere with cordless and low-power telephones. Conversely, RFI from high-power telephones can cause spurious characters to appear on the switch monitor.

RFI is defined as any EMI with a frequency above 10 kHz. This type of interference can travel from the switch to other devices through the power cable and power source or through the air as transmitted radio waves. The Federal Communications Commission (FCC) publishes specific regulations to limit the amount of EMI and RFI that are emitted by computing equipment. Each switch meets these FCC regulations.

To reduce the possibility of EMI and RFI, follow these guidelines:

- Cover all open expansion slots with a blank filler plate.
- Always use shielded cables with metal connector shells for attaching peripherals to the switch.

When wires are run for any significant distance in an electromagnetic field, interference can occur to the signals on the wires with the following implications:

- Bad wiring can result in radio interference emanating from the plant wiring.
- Strong EMI, especially when it is caused by lightning or radio transmitters, can destroy the signal drivers and receivers in the chassis and even create an electrical hazard by conducting power surges through lines into equipment.



Note To predict and prevent strong EMI, you need to consult experts in radio frequency interference (RFI).

The wiring is unlikely to emit radio interference if you use a twisted-pair cable with a good distribution of grounding conductors. If you exceed the recommended distances, use a high-quality twisted-pair cable with one ground conductor for each data signal when applicable.



Caution If the wires exceed the recommended distances, or if wires pass between buildings, give special consideration to the effect of a lightning strike in your vicinity. The electromagnetic pulse that is caused by lightning or other high-energy phenomena can easily couple enough energy into unshielded conductors to destroy electronic switches. You will want to consult experts in electrical surge suppression and shielding if you had similar problems in the past.

Shock and Vibration Requirements

The switch has been shock- and vibration-tested for operating ranges, handling, and earthquake standards.

Grounding Requirements

The switch is sensitive to variations in voltage that is supplied by the power sources. Overvoltage, undervoltage, and transients (or spikes) can erase data from memory or cause components to fail. To protect against these types of problems, ensure that there is an earth-ground connection for the switch. You can connect the grounding pad on the switch either directly to the earth-ground connection or to a fully bonded and grounded rack.

When you properly install the chassis in a grounded rack, the switch is grounded because it has a metal-to-metal connection to the rack. Alternatively, you can ground the chassis by using a customer-supplied grounding cable that meets your local and national installation requirements. For U.S. installations, we recommend 6-AWG wire. Connect your grounding cable to the chassis with a grounding lug (provided in the switch accessory kit) and to the facility ground.



Note You automatically ground AC power supplies when you connect them to AC power sources. For DC power supplies, you must connect a grounding wire when wiring the power supply to the DC power source.



Note An electrical conducting path shall exist between the product chassis and the metal surface of the enclosure or rack in which it is mounted or to a grounding conductor. Electrical continuity shall be provided by using thread-forming type mounting screws that remove any paint or non-conductive coatings and establish a metal-to-metal contact. Any paint or other non-conductive coatings shall be removed on the surfaces between the mounting hardware and the enclosure or rack. The surfaces shall be cleaned and an antioxidant applied before installation.

Planning for Power Requirements

The switch includes two power supplies (1-to-1 redundancy with current sharing) in one of the following combinations:

- Two 500-W AC power supplies
- Two 1200-W HVAC/HVDC power supplies
- Two 930-W DC power supplies



Note Both power supplies must be the same type. Do not mix AC, DC, and HVAC/HVDC power supplies in the same chassis.



Note For $n+1$ redundancy, you can use one or two power sources for the two power supplies. For $n+n$ redundancy, you must use two power sources and connect each power supply to a separate power source.



Note Some of the power supply modules have rating capabilities that exceed the switch requirements. When calculating your power requirements, use the switch requirements to determine the amount of power that is required for the power supplies.

To minimize the possibility of circuit failure, make sure that each power-source circuit that is used by the switch is dedicated to the switch.



Note For AC input application, please refer to the following statement:



Warning **Statement 1005**—Circuit Breaker when using AC power supplies

This product relies on the building's installation for short-circuit (overcurrent) protection. Ensure that the protective devices are rated not greater than 20A (North America), 16A (Europe), and 13A (UK).



Note For DC input application, please refer to the following statement:



Warning **Statement 1005**—Circuit Breaker when using DC power supplies

This product relies on the building's installation for short-circuit (overcurrent) protection.

- Ensure that the protective devices are rated not greater than 30A when the switch is powered with regular DC power supplies (rated 48-60VDC).
- Ensure that the protective devices are rated not greater than 10A when the switch is powered with HVDC power supplies (rated 240-350VDC).

**Warning Statement 1033**

Connect the unit only to DC power source that complies with the Safety Extra-Low Voltage (SELV) requirements in IEC 60950 based safety standards.



Note We recommend 8-AWG wire for DC installations in the U.S.



Note For the power cables to use with the power supplies, see [Power Cable Specifications, on page 53](#).

Airflow Requirements

The switch is positioned with its ports in either the front or the rear of the rack depending on your cabling and maintenance requirements. You must have fan and power supply modules that move the coolant air from the cold aisle to the hot aisle in one of the following ways:

- Port-side exhaust airflow—Cool air enters the chassis through the fan and power supply modules in the cold aisle and exhausts through the port end of the chassis in the hot aisle.
- Port-side intake airflow—Cool air enters the chassis through the port end in the cold aisle and exhausts through the fan and power supply modules in the hot aisle.

You can identify the airflow direction of each fan and power supply module by its coloring as follows:

- Blue coloring indicates port-side exhaust airflow.
- Burgundy coloring indicates port-side intake airflow.
- White coloring on HVAC/HVDC power supplies indicates dual-direction airflow.



Note To prevent the switch from overheating and shutting down, you must position the air intake for the switch in a cold aisle. The fan and power supply modules must have the same direction of airflow (even if their coloring is different). If you must change the airflow direction for the switch, you must shutdown the switch before changing the modules.

Rack and Cabinet Requirements

You can install the following types of racks or cabinets for your switch:

- Standard perforated cabinets
- Solid-walled cabinets with a roof fan tray (bottom-to-top cooling)

- Standard open four-post Telco racks

Work with your cabinet vendors to determine which of their cabinets meet the following requirements or see the Cisco Technical Assistance Center (TAC) for recommendations:

- Use a standard 19-inch (48.3-cm), four-post Electronic Industries Alliance (EIA) cabinet or rack with mounting rails that conform to English universal hole spacing per section 1 of the ANSI/EIA-310-D-1992 standard.
- The depth of a four-post rack must be 24 to 32 inches (61.0 to 81.3 cm) between the front and rear mounting rails (for proper mounting of the bottom-support brackets or other mounting hardware).
- Required clearances between the chassis and the edges of its rack or the interior of its cabinet are as follows:
 - 4.5 inches (11.4 cm) between the front of the chassis and the interior of the cabinet (required for cabling).
 - 3.0 inches (7.6 cm) between the rear of the chassis and the interior of the cabinet (required for airflow in the cabinet if used).
 - No clearance is required between the chassis and the sides of the rack or cabinet (no side airflow).

Also, you must have power receptacles that are located within reach of the power cords that are used with the switch.



Warning **Statement 1048**—Rack Stabilization

The rack stabilizing mechanism must be in place, or the rack must be bolted to the floor before installation or servicing. Failure to stabilize the rack can cause bodily injury.

Clearance Requirements

Provide the chassis with adequate clearance between the chassis and any other rack, device, or structure so that you can properly install the chassis. Provide the chassis with adequate clearance to route cables, provide airflow, and maintain the switch. For the clearances required for an installation of this chassis in a four-post rack, see the following figure.

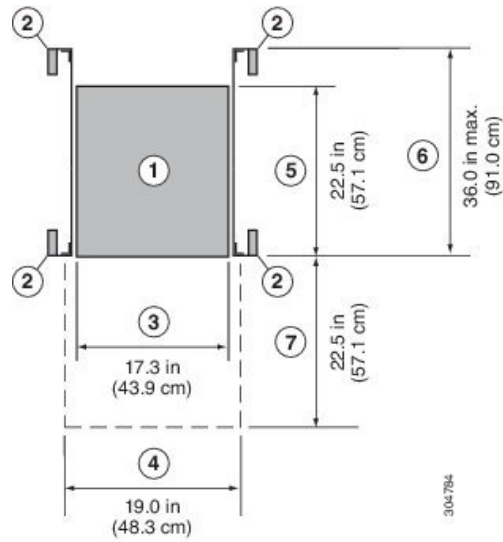

1	Chassis	5	Depth of the chassis
2	Vertical rack-mount posts and rails	6	Maximum extension of the bottom-support rails 36.0 in (91.0 cm)
3	Chassis width 17.3 in (43.9 cm)	7	Depth of the front clearance area (equal to the depth of the chassis).
4	Width of the front clearance area (equal to the width of the chassis with two rack-mount brackets that are attached to it). 19.0 in (43.3 cm)		



Note Both the front and rear of the chassis must be open to both aisles for airflow.



CHAPTER 3

Installing the Switch Chassis

- [Safety](#), on page 13
- [Installation Options with Rack-Mount Kits](#), on page 16
- [Airflow Considerations](#), on page 17
- [Installation Guidelines](#), on page 17
- [Unpacking and Inspecting the Switch](#), on page 18
- [Installing the Switch Using the NXK-ACC-KIT-1RU Rack-Mount Kit](#), on page 19
- [Installing the Switch Using the N3K-C3064-ACC-KIT Rack-Mount Kit](#), on page 23
- [Installing the Airflow Sleeve \(N9K-AIRFLOW-SLV\)](#), on page 27
- [Grounding the Chassis](#), on page 29
- [Starting the Switch](#), on page 30

Safety

Before you install, operate, or service the switch, see the *Regulatory, Compliance, and Safety Information for the Cisco Nexus 3000 and 9000 Series* for important Safety Information.



Warning **Statement 1071**—Warning Definition

IMPORTANT SAFETY INSTRUCTIONS

Before you work on any equipment, be aware of the hazards involved with electrical circuitry and be familiar with standard practices for preventing accidents. Read the installation instructions before using, installing, or connecting the system to the power source. Use the statement number provided at the end of each warning statement to locate its translation in the translated safety warnings for this device.

SAVE THESE INSTRUCTIONS



Warning **Statement 1089**—Instructed and Skilled Person Definitions

An instructed person is someone who has been instructed and trained by a skilled person and takes the necessary precautions when working with equipment.

A skilled person or qualified personnel is someone who has training or experience in the equipment technology and understands potential hazards when working with equipment.

**Warning Statement 1004**—Installation Instructions

Read the installation instructions before using, installing, or connecting the system to the power source.

**Warning Statement 1040**—Product Disposal

Ultimate disposal of this product should be handled according to all national laws and regulations.

**Warning Statement 1074**—Comply with Local and National Electrical Codes

To reduce risk of electric shock or fire, installation of the equipment must comply with local and national electrical codes.

**Warning Statement 371**—Power Cable and AC Adapter

When installing the product, use the provided or designated connection cables, power cables, AC adapters, and batteries. Using any other cables or adapters could cause a malfunction or a fire. Electrical Appliance and Material Safety Law prohibits the use of UL-certified cables (that have the "UL" or "CSA" shown on the cord), not regulated with the subject law by showing "PSE" on the cord, for any other electrical devices than products designated by Cisco.

**Note Statement 407**—Japanese Safety Instruction

You are strongly advised to read the safety instruction before using the product.

<https://www.cisco.com/web/JP/techdoc/pldoc/pldoc.html>

When installing the product, use the provided or designated connection cables/power cables/AC adapters.

〈製品仕様における安全上の注意〉
www.cisco.com/web/JP/techdoc/index.html

接続ケーブル、電源コードセット、ACアダプタ、バッテリーなどの部品は、必ず添付品または指定品をご使用ください。添付品・指定品以外をご使用になると故障や動作不良、火災の原因となります。また、電源コードセットは弊社が指定する製品以外の電気機器には使用できないためご注意ください。

**Warning Statement 1017**—Restricted Area

This unit is intended for installation in restricted access areas. Only skilled, instructed, or qualified personnel can access a restricted access area.

**Warning Statement 1030—Equipment Installation**

Only trained and qualified personnel should be allowed to install, replace, or service this equipment.

**Warning Statement 1091—Installation by an Instructed Person**

Only an instructed person or skilled person should be allowed to install, replace, or service this equipment. See statement 1089 for the definition of an instructed or skilled person.

**Warning Statement 1028—More Than One Power Supply**

This unit might have more than one power supply connection. To reduce risk of electric shock, remove all connections to de-energize the unit.

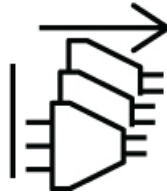
**Warning Statement 1003—DC Power Disconnection**

Before performing any of the following procedures, ensure that power is removed from the DC circuit.

**Warning Statement 1046—Installing or Replacing the Unit**

To reduce risk of electric shock, when installing or replacing the unit, the ground connection must always be made first and disconnected last.

**Warning Statement 1022—Disconnect Device**

To reduce risk of electric shock and fire, a readily accessible two-poled disconnect device must be incorporated in the fixed wiring.

**Warning Statement 1033—Safety Extra-Low Voltage (SELV)—IEC 60950/ES1—IEC 62368 DC Power Supply**

To reduce risk of electric shock, connect the unit only to a DC power source that complies with the SELV requirements in IEC 60950-based safety standards or ES1 requirements in IEC 62368-based safety standards.



Warning Statement 1024—Ground Conductor

This equipment must be grounded. To reduce the risk of electric shock, never defeat the ground conductor or operate the equipment in the absence of a suitably installed ground conductor. Contact the appropriate electrical inspection authority or an electrician if you are uncertain that suitable grounding is available.



Warning Statement 1252—Equipment Grounding

This equipment must be grounded. To reduce the risk of electric shock, the power cord, plug, or combination must be connected to a properly grounded electrode, outlet, or terminal.



Warning Statement 1032—Lifting the Chassis

To prevent personal injury or damage to the chassis, never attempt to lift or tilt the chassis using the handles on modules, such as power supplies, fans, or cards. These types of handles are not designed to support the weight of the unit.



Warning Statement 1006—Chassis Warning for Rack-Mounting and Servicing

To prevent bodily injury when mounting or servicing this unit in a rack, you must take special precautions to ensure that the system remains stable. The following guidelines are provided to ensure your safety:

- This unit should be mounted at the bottom of the rack if it is the only unit in the rack.
 - When mounting this unit in a partially filled rack, load the rack from the bottom to the top with the heaviest component at the bottom of the rack.
 - If the rack is provided with stabilizing devices, install the stabilizers before mounting or servicing the unit in the rack.
-

Installation Options with Rack-Mount Kits

The rack-mount kit enables you to install the switch into racks of varying depths. You can position the switch with easy access to either the port connections or the fan and power supply modules.

You can install the switch using the following rack-mount options:

- Rack-mount kit (NXK-ACC-KIT-1RU) which you can order from Cisco. This option offers you easy installation, greater stability, increased weight capacity, added accessibility, and improved removability with front and rear removal.
 - When installing the NXK-ACC-KIT-1RU rack-mount kit, the distance between the outside face of the front mounting rail and the outside face of the back mounting rail should be 25.37 to 35 inches (64.43 to 88.9 cm) to allow for rear-bracket installation.

- Rack-mount kit (N3K-C3064-ACC-KIT) which you can order from Cisco.
 - When installing the N3K-C3064-ACC-KIT rack-mount kit, the distance between the outside face of the front mounting rail and the outside face of the back mounting rail should be 25 to 35 inches (63.5 to 88.9 cm) to allow for rear-bracket installation.

The rack or cabinet that you use must meet the requirements listed the in [General Requirements for Cabinets and Racks, on page 45](#) section.



Note You are responsible for verifying that your rack and rack-mount hardware comply with the guidelines that are described in this doc.

Airflow Considerations

The switch comes with fan and power supply modules that have either port-side intake or port-side exhaust airflow for cooling the switch. If you are positioning the port end of the switch in a cold aisle, make sure that the switch has port-side intake fan modules with burgundy coloring. If you are positioning the fan and power supply modules in a cold aisle, make sure that the switch has port-side exhaust fan modules with blue colorings. All fan modules must have the same direction of airflow.

Installation Guidelines

When installing the switch, follow these guidelines:

- Ensure that there is adequate clearance space around the switch to allow for servicing the switch and for adequate airflow.
- Ensure that you are positioning the switch in a rack so that it takes in cold air from the cold aisle and exhausts air to the hot aisle. If there is blue coloring on the fan modules, the switch is configured for port-side exhaust airflow and you must position the module side of the switch in a cold aisle. If there is burgundy coloring on the fan modules, the switch is configured for port-side intake airflow and you must position the port side of the switch in a cold aisle.
- Ensure that the chassis can be adequately grounded. If the switch is not mounted in a grounded rack, we recommend connecting the system ground on the chassis directly to an earth ground.
- Ensure that the site power meets the power requirements for the switch. If available, you can use an uninterruptible power supply (UPS) to protect against power failures.



Caution Avoid UPS types that use ferroresonant technology. These UPS types can become unstable with the switch, which can have substantial current draw fluctuations because of fluctuating data traffic patterns.

- Ensure that circuits are sized according to local and national codes. Typically, this often requires one or both of the following:

- AC power supplies typically require at least a 15-A or 20-A AC circuit, 100 to 240 VAC, and a frequency of 50 to 60 Hz.



Caution To prevent loss of input power, ensure the total maximum loads on the circuits supplying power to the switch are within the current ratings for the wiring and breakers.



Note For AC input application, please refer to the statement below:



Warning **Statement 1005**—Circuit Breaker

This product relies on the building's installation for short-circuit (overcurrent) protection. Ensure that the protective devices is rated not greater than 20A (North America), 16A (Europe), and 13A (UK).



Note For DC input application, please refer to the statement below:



Warning **Statement 1005**—Circuit Breaker

This product relies on the building's installation for short-circuit (overcurrent) protection. Ensure that the protective devices is rated not greater than 40A for the regular DC power supplies (rated 48-60VDC) and 10A for the HVDC power supplies.

Unpacking and Inspecting the Switch

Before you install the switch, be sure to unpack and inspect the switch for damage or missing components. If anything is missing or damaged, contact your customer service representative immediately.



Tip Keep the shipping container in case the chassis requires shipping at a later time.

Before you begin

Before you unpack the switch and before you handle any switch components, be sure that you are wearing a grounded electrostatic discharge (ESD) strap. To ground the strap, attach it directly to an earth ground or to a grounded rack or grounded chassis (there must be a metal-to-metal connection to the earth ground).

-
- Step 1** Compare the shipment to the equipment list provided by your customer service representative and verify that you have received all items, including the following:
- Accessory Kit
- Step 2** Check for damage and report any discrepancies or damage to your customer service representative. Have the following information ready:
- Invoice number of shipper (see packing slip)
 - Model and serial number of the damaged unit
 - Description of damage
 - Effect of damage on the installation
- Step 3** Check to be sure that each of the power supply and the fan tray modules have the expected direction of airflow as follows:
- Port-side intake airflow modules
 - Burgundy (fan modules, AC power supplies, and DC power supplies)
 - Port-side exhaust airflow modules
 - Blue (fan modules, AC power supplies, and DC power supplies)
 - Dual-direction airflow power-supply modules
 - White (see the color of the fan modules to determine the airflow direction used)
- Note** All power supplies and fan modules must have the same direction of airflow.
-

Installing the Switch Using the NXK-ACC-KIT-1RU Rack-Mount Kit

To install the switch, you must attach front and rear mounting brackets to the switch, install slider rails on the rear of the rack, slide the switch onto the slider rails, and secure the switch to the front of the rack. Typically, the front of the rack is the side easiest to access for maintenance.



Note You must supply the eight 10-32 or 12-24 screws required to mount the slider rails and switch to the rack.

Before you begin

- You have inspected the switch shipment to ensure that you have everything ordered.
- Make sure that the switch rack-mount kit includes the following parts:

- Front rack-mount brackets (2)
 - Rear rack-mount brackets (2)
 - Slider rails (2)
 - M4 x 0.7 x 8-mm Phillips pan-head screws (10)
- The rack is installed and secured to its location.

Step 1

Install two front rack-mount brackets and the two rear rack-mount brackets to the switch as follows:

a) Determine which end of the chassis is to be located in the cold aisle as follows:

- If the switch has port-side intake modules (fan modules with burgundy coloring), position the switch so that its ports will be in the cold aisle.
- If the switch has port-side exhaust modules (fan modules with blue coloring), position the switch so that its fan and power supply modules will be in the cold aisle.

b) Position the front rack-mount bracket and the rear rack-mount bracket so that its screw holes are aligned to the screw holes on the side of the chassis.

Note You can align the holes in the rack-mount bracket to the holes on the side of the chassis (see the two ways to mount these brackets on a typical chassis, in following figure). The holes that you use depend on the requirements of your rack and the amount of clearance required for interface cables (3 inches [7.6 mm] minimum) and module handles (1 inch [2.5 mm] minimum).

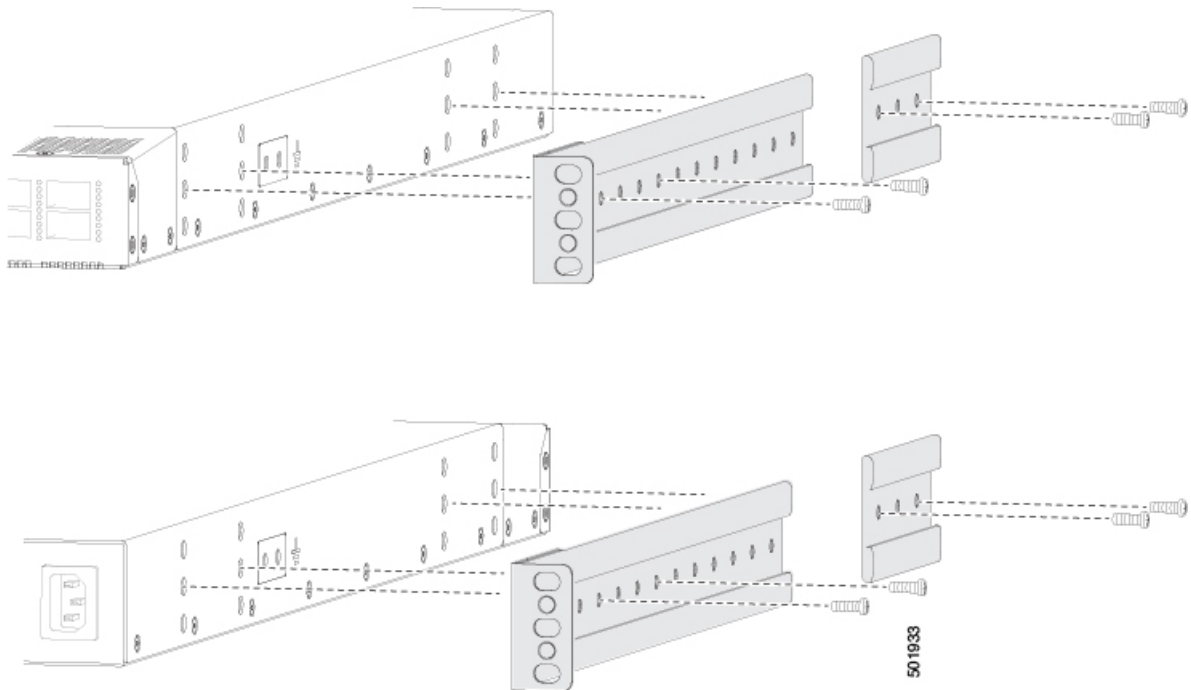

c) Secure the front-mount bracket and the back-mount bracket to the chassis using four M4 screws and tighten each screw to 12 in-lb (1.36 N·m) of torque.

- d) Repeat Step 1 for the other front rack-mount bracket and the other back-mount bracket on the other side of the switch and be sure to position that bracket the same distance from the front of the switch.

Note Depending on the chassis depth, the back rack-mount bracket may not fit. In that case the back rack-mount bracket is not needed.

Step 2 If you are not installing the chassis into a grounded rack, you must attach a customer-supplied grounding wire to the chassis as explained in the [Grounding the Chassis, on page 29](#) section. If you are installing the chassis into a grounded rack, you can skip this step.

Step 3 Install the slider rails on the rack or cabinet as follows:

- Determine which two posts of the rack or cabinet you should use for the slider rails. Of the four vertical posts in the rack or cabinet, two will be used for the front mount brackets attached to the easiest accessed end of the chassis, and the other two posts will have the slider rails.
- Position a slider rail at the desired level on the back side of the rack and use 12-24 screws or 10-32 screws, depending on the rack thread type, to attach the rails to the rack (see the following figure). Tighten 12-24 screws to 30 in-lb (3.39 N·m) of torque and tighten 10-32 screws to 20 in-lb (2.26 N·m) of torque.

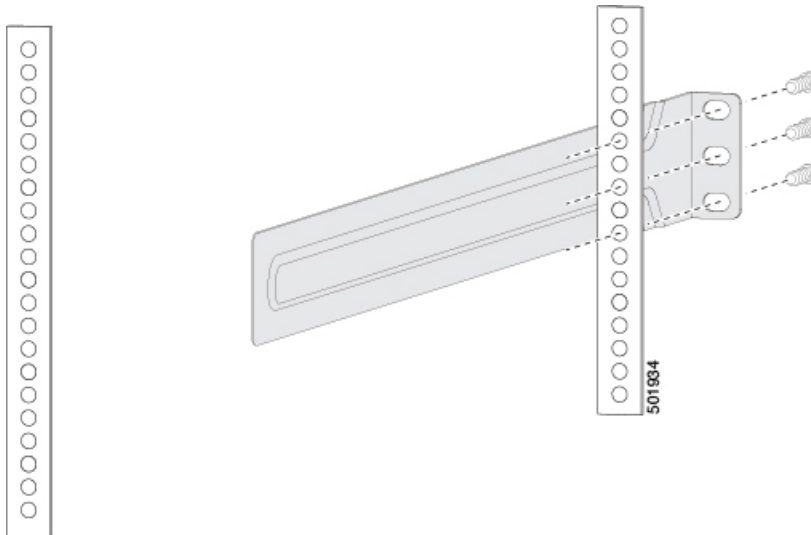

- c) Repeat Step 3 to attach the other slider rail to the other side of the rack.

To make sure that the slider rails are at the same level, you should use a level tool, tape measure, or carefully count the screw holes in the vertical mounting rails.

Step 4 Insert the switch into the rack and attach it as follows:

- Holding the switch with both hands, position the two rear rack-mount brackets on the switch between the rack or cabinet posts that do not have slider rails attached to them (see the following figure).

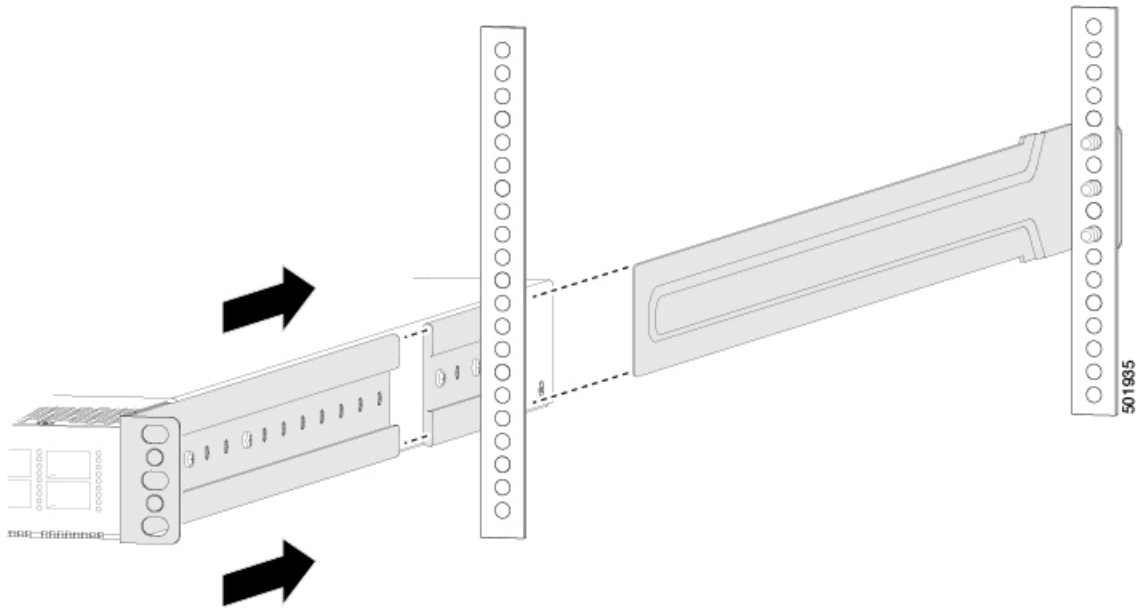

- b) Align the two rear rack-mount guides on either side of the switch with the slider rails installed in the rack. Slide the rack-mount guides onto the slider rails, and then gently slide the switch all the way into the rack until the front rack-mount brackets come in contact with two rack or cabinet posts.
- c) Holding the chassis level, insert screws (12-24 or 10-32, depending on the rack type) in each of the two front rack-mount brackets (using a total of six screws) and into the cage nuts or threaded holes in the vertical rack-mounting rails (see the following figure).

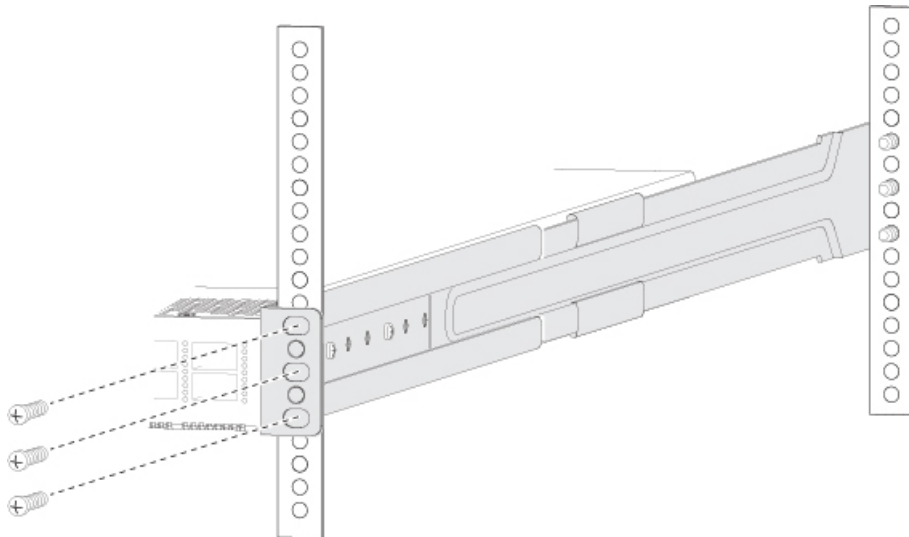

- d) Tighten the 10-32 screws to 20 in-lb (2.26 N·m) or tighten the 12-24 screws to 30 in-lb (3.39 N·m).

Step 5

If you attached a grounding wire to the chassis grounding pad, connect the other end of the wire to the facility ground.

Installing the Switch Using the N3K-C3064-ACC-KIT Rack-Mount Kit

To install the switch, you must attach front and rear mounting brackets to the switch, install slider rails on the rear of the rack, slide the switch onto the slider rails, and secure the switch to the front of the rack. Typically, the front of the rack is the side easiest to access for maintenance.



Note You must supply the eight 10-32 or 12-24 screws required to mount the slider rails and switch to the rack.

Before you begin

- You have inspected the switch shipment to ensure that you have everything ordered.
- Make sure that the switch rack-mount kit includes the following parts:
 - Front rack-mount brackets (2)
 - Rear rack-mount brackets (2)
 - Slider rails (2)
 - M4 x 0.7 x 8-mm Phillips countersink screws (12)
- The rack is installed and secured to its location.

Step 1

Install two front-mount brackets to the switch as follows:

a) Determine which end of the chassis is to be located in the cold aisle as follows:

- If the switch has port-side intake modules (fan modules with burgundy coloring), position the switch so that its ports will be in the cold aisle.
- If the switch has port-side exhaust modules (fan modules with blue coloring), position the switch so that its fan and power supply modules will be in the cold aisle.

b) Position a front-mount bracket so that four of its screw holes are aligned to the screw holes on the side of the chassis.

Note You can align any four of the holes in the front rack-mount bracket to four of the six screw holes on the side of the chassis (see the two ways to mount these brackets on a typical chassis, in following figure). The holes that you use depend on the requirements of your rack and the amount of clearance required for interface cables (3 inches [7.6 mm] minimum) and module handles (1 inch [2.5 mm] minimum).

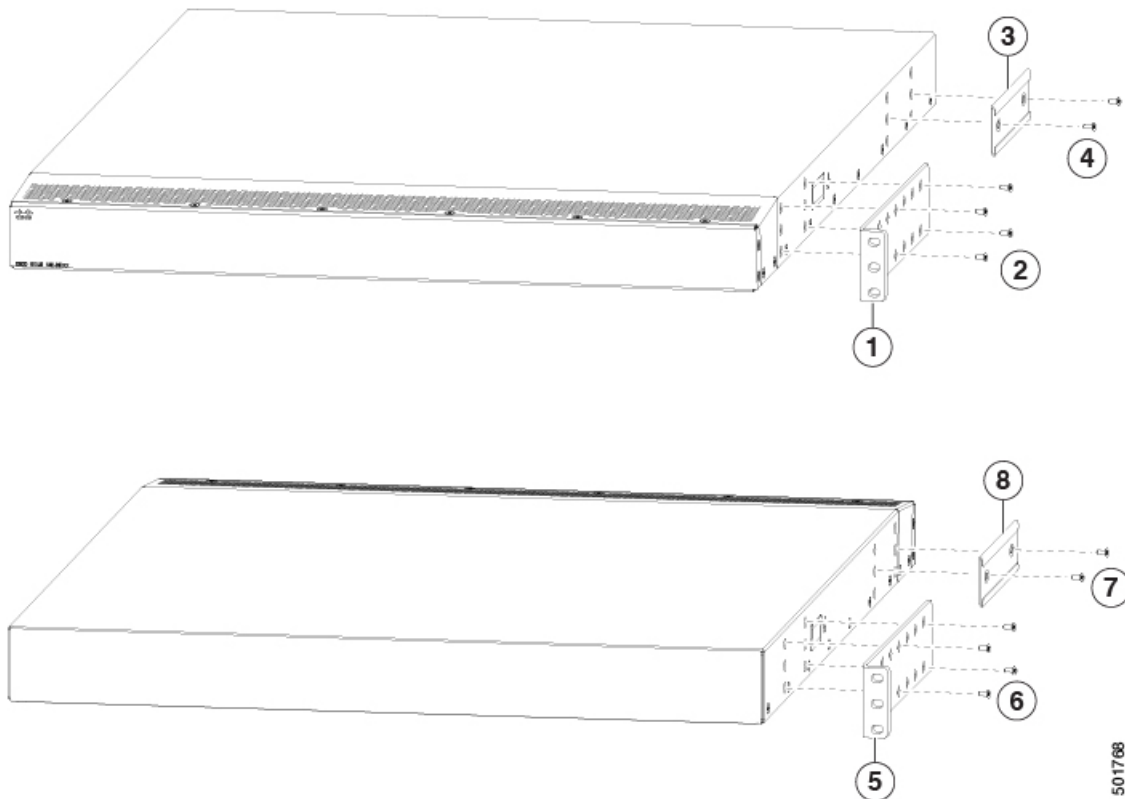

1	Front rack-mount bracket aligned to the port end of the chassis	5	Front rack-mount bracket aligned to the module end of the chassis
2	Four M4 screws used to attach the bracket to the chassis	6	Four M4 screws used to attach the bracket to the chassis
3	Rear rack-mount guide aligned to the module end of the chassis	7	Two M4 screws used to attach the bracket to the chassis
4	Two M4 screws used to attach the bracket to the chassis	8	Rear rack-mount guide aligned to the port end of the chassis

- c) Secure the front-mount bracket to the chassis using four M4 screws and tighten each screw to 12 in-lb (1.36 N·m) of torque.
- d) Repeat Step 1 for the other front rack-mount bracket on the other side of the switch and be sure to position that bracket the same distance from the front of the switch.

Step 2 Install the two rear rack-mount brackets on the chassis as follows:

- a) Align the two screw holes on a rear rack-mount bracket to the middle two screw holes in the remaining six screw holes on a side of the chassis. If you are aligning the guide to holes that are near the port connections end of the chassis, see Callout 3 in the previous figure. Otherwise, see Callout 7 in the previous figure.
- b) Attach the guide to the chassis using two M4 screws (see Callout 4 or 8 in the previous figure). Tighten the screws to 12 in-lb (1.36 N·m) of torque.
- c) Repeat Step 2 for the other rear rack-mount bracket on the other side of the switch.

Step 3 If you are not installing the chassis into a grounded rack, you must attach a customer-supplied grounding wire to the chassis as explained in the [Grounding the Chassis, on page 29](#) section. If you are installing the chassis into a grounded rack, you can skip this step.

Step 4 Install the slider rails on the rack or cabinet as follows:

- a) Determine which two posts of the rack or cabinet you should use for the slider rails. Of the four vertical posts in the rack or cabinet, two will be used for the front mount brackets attached to the easiest accessed end of the chassis, and the other two posts will have the slider rails.
- b) Position a slider rail at the desired level on the back side of the rack and use two 12-24 screws or two 10-32 screws, depending on the rack thread type, to attach the rails to the rack (see the following figure). Tighten 12-24 screws to 30 in-lb (3.39 N·m) of torque and tighten 10-32 screws to 20 in-lb (2.26 N·m) of torque.

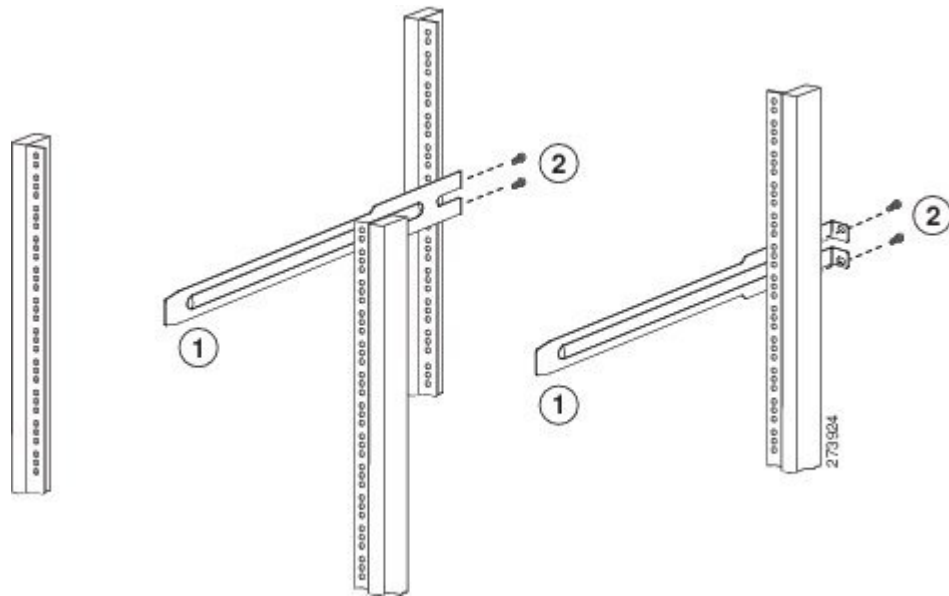

1	Slider rail with screw holes aligned to screw holes in rack	2	Two customer-supplied 12-24 or 10-32 screws used to attach each slider rail to the rack
---	---	---	---

- c) Repeat Step 3 to attach the other slider rail to the other side of the rack.

To make sure that the slider rails are at the same level, you should use a level tool, tape measure, or carefully count the screw holes in the vertical mounting rails.

Step 5 Insert the switch into the rack and attach it as follows:

- a) Holding the switch with both hands, position the two rear rack-mount brackets on the switch between the rack or cabinet posts that do not have slider rails attached to them (see the following figure).

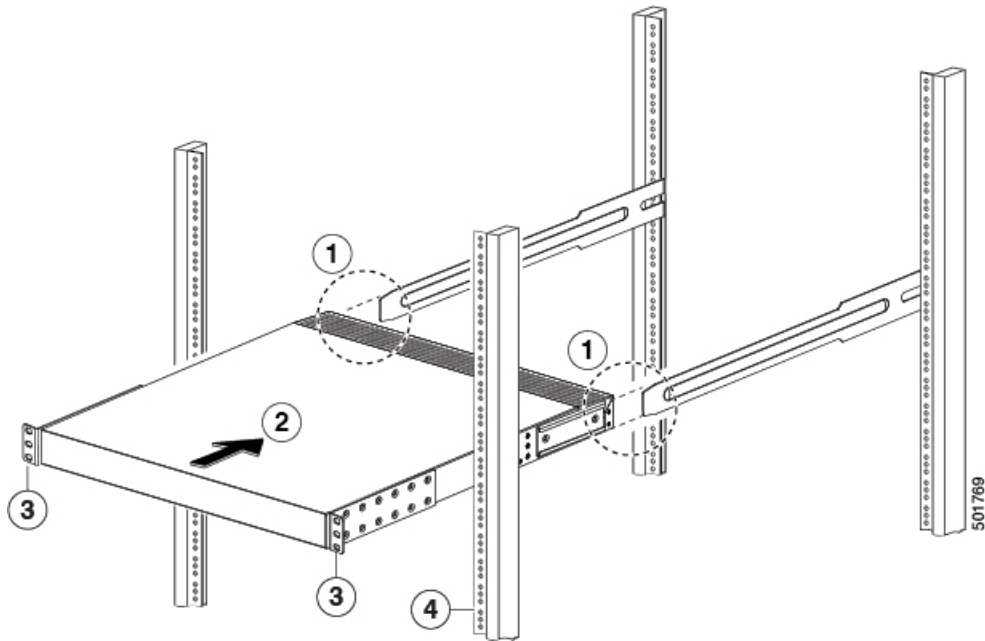

1	Align the two rear rack-mount bracket guides with the slider rails installed in the rack.	3	Front-mount brackets.
2	Slide the rack-mount guides onto the slider rails until the front rack-mount brackets come in contact with the front rack-mount rails.	4	Mounting rails on rack or cabinet posts.

- b) Align the two rear rack-mount guides on either side of the switch with the slider rails installed in the rack. Slide the rack-mount guides onto the slider rails, and then gently slide the switch all the way into the rack until the front rack-mount brackets come in contact with two rack or cabinet posts.
- c) Holding the chassis level, insert two screws (12-24 or 10-32, depending on the rack type) in each of the two front rack-mount brackets (using a total of four screws) and into the cage nuts or threaded holes in the vertical rack-mounting rails (see the following figure).

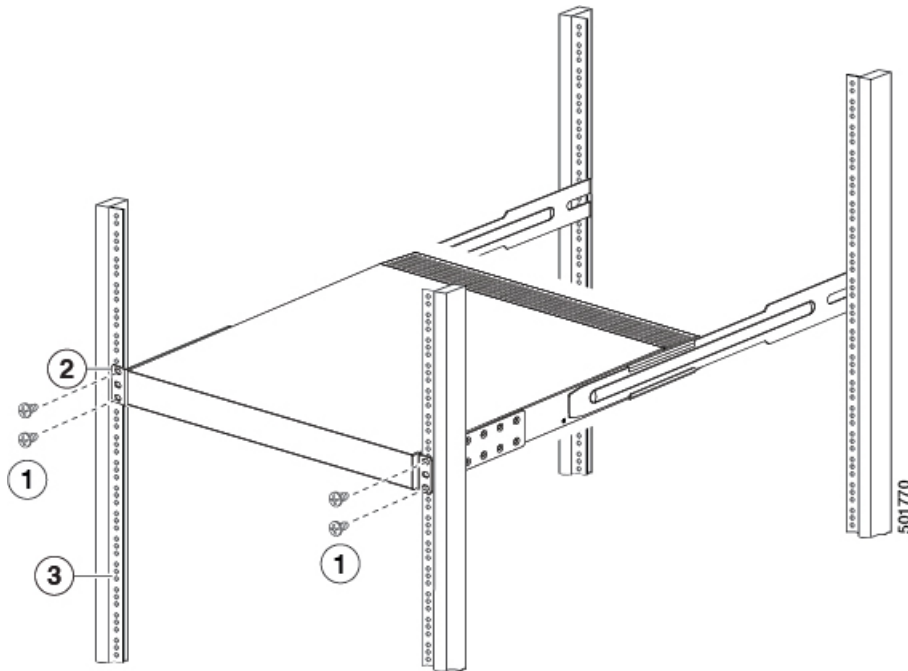

1	Fasten the chassis to the front of the rack with two 12-24 or 10-32 screws on each side.	3	Mounting rails on rack or cabinet posts.
2	Front-mount bracket.		

d) Tighten the 10-32 screws to 20 in-lb (2.26 N·m) or tighten the 12-24 screws to 30 in-lb (3.39 N·m).

Step 6 If you attached a grounding wire to the chassis grounding pad, connect the other end of the wire to the facility ground.

Installing the Airflow Sleeve (N9K-AIRFLOW-SLV)

The airflow sleeve (N9K-AIRFLOW-SLV) is installed to allow proper airflow, so that the switch is properly cooled.

Table 2: Airflow Sleeve (N9K-AIRFLOW-SLV) Minimum and Maximum Rack Rail Depth.

Chassis	Minimum Rack Depth	Maximum Rack Depth
N9K-C92348GC-X	636.49 mm	748.25 mm
N9K-C9316D-GX	824.80 mm	916.60 mm
N9K-C9332C	794.20 mm	898.70 mm
N9K-C9332D-GX2B	824.00 mm	915.80 mm
N9K-C9336C-FX2	315.90 mm	355.90 mm

Chassis	Minimum Rack Depth	Maximum Rack Depth
N9K-C9336C-FX2-E	806.90 mm	898.70 mm
N9K-C9348GC-FXP	672.49 mm	764.29 mm
N9K-C93108TC-FX	781.29 mm	873.09 mm
N9K-C93108TC-FX3P	672.49 mm	769.69 mm
N9K-C93180YC-FX	781.29 mm	873.09 mm
N9K-C93180YC-FX3	672.49 mm	784.25 mm
N9K-C93180YC-FX3S	672.49 mm	784.25 mm
N9K-C93600CD-GX	824.80 mm	916.60 mm



Note You supply the screws to mount the airflow sleeve.

Before you begin

- Verify that your shipment is complete.
- Install your rack in a secure location.

Insert the airflow sleeve into the rack and attach it as follows:

- Holding the airflow sleeve (N9K-AIRFLOW-SLV) with both hands, position it in front of the fan side of the chassis.
- Holding the airflow sleeve level, insert screws (12-24 or 10-32, depending on the rack type) in each of the two front rack-mount flanges (using a total of two screws) and into the cage nuts or threaded holes in the vertical rack-mounting rails (see the following figure).

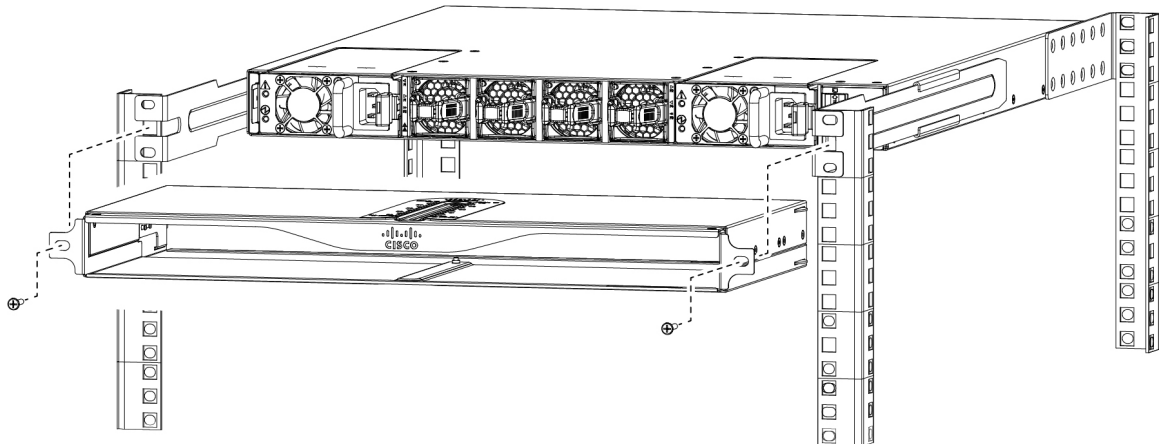

- Tighten the 10-32 screws to 20 in-lb (2.26 N·m) or tighten the 12-24 screws to 30 in-lb (3.39 N·m).

Grounding the Chassis

The switch chassis is automatically grounded when you properly install the switch in a grounded rack with metal-to-metal connections between the switch and rack.



Note An electrical conducting path shall exist between the product chassis and the metal surface of the enclosure or rack in which it is mounted or to a grounding conductor. Electrical continuity shall be provided by using thread-forming type mounting screws that remove any paint or non-conductive coatings and establish a metal-to-metal contact. Any paint or other non-conductive coatings shall be removed on the surfaces between the mounting hardware and the enclosure or rack. The surfaces shall be cleaned and an antioxidant applied before installation.

You can also ground the chassis, which is required if the rack is not grounded, by attaching a customer-supplied grounding cable. Attach the cable to the chassis grounding pad and the facility ground.



Warning **Statement 1024**—Ground Conductor

This equipment must be grounded. To reduce the risk of electric shock, never defeat the ground conductor or operate the equipment in the absence of a suitably installed ground conductor. Contact the appropriate electrical inspection authority or an electrician if you are uncertain that suitable grounding is available.



Warning **Statement 1046**—Installing or Replacing the Unit

To reduce risk of electric shock, when installing or replacing the unit, the ground connection must always be made first and disconnected last.

Before you begin

Before you can ground the chassis, you must have a connection to the earth ground for the data center building.

-
- Step 1** Use a wire-stripping tool to remove approximately 0.75 inch (19 mm) of the covering from the end of the grounding wire. We recommend 6-AWG wire for the U.S. installations.
- Step 2** Insert the stripped end of the grounding wire into the open end of the grounding lug. Use a crimping tool to crimp the lug to the wire, see the following figure. Verify that the ground wire is securely attached to the grounding lug by attempting to pull the wire out of the crimped lug.

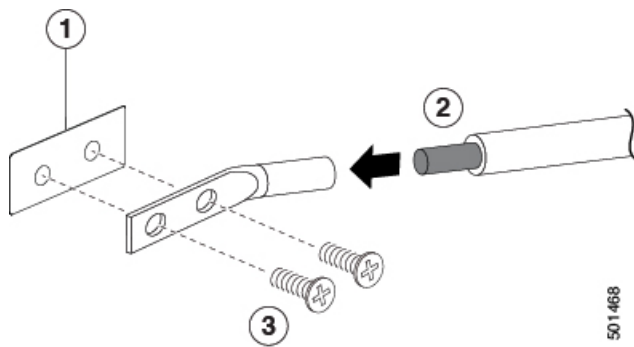

1	Chassis grounding pad	3	2 M4 screws are used to secure the grounding lug to the chassis
2	Grounding cable, with 0.75 in. (19 mm) of insulation that is stripped from one end, which is inserted into the grounding lug and crimped in place		

Step 3 Secure the grounding lug to the chassis grounding pad with two M4 screws, see the previous figure. Tighten the screws to 11 to 15 in-lb (1.24 to 1.69 N·m) of torque.

Step 4 Prepare the other end of the grounding wire and connect it to the facility ground.

Starting the Switch

You start the switch by connecting it to its dedicated power source. If you need $n+1$ redundancy, you must connect each of the power supplies to one or two power sources. If you need $n+n$ redundancy, you must connect each power supply in a switch to a different power source.



Note This equipment is designed to boot up in less than 30 minutes, dependent on its neighboring devices being fully up and running.

Before you begin

- The switch must be installed and secured to a rack or cabinet.
- The switch must be adequately grounded.
- The rack must be close enough to the dedicated power source so that you can connect the switch to the power source by using a designated power cables.
- You have the designated power cables for the power supplies that you are connecting to the dedicated power sources.



Note Depending on the outlet receptacle on your AC power distribution unit, you might need an optional jumper power cord to connect the switch to your outlet receptacle.

- The switch is not connected to the network (this includes any management or interface connections).
- The fan and power supply modules are fully secured in their chassis slots.

-
- Step 1** For each AC power supply, do the following:
- a) Using the recommended AC power cable for your country or region, connect one end to the AC power supply.
 - b) Connect the other end of the power cable to the AC power source.
- Step 2** For each HVAC/HVDC power supply, connect it to a power source as follows:
- a) Using the recommended high voltage power cable for your country or region, connect the Anderson Power Saf-D-Grid connector on the power cable to the power receptacle on the power supply. Make sure that the connector clicks when fully pushed into the receptacle.
 - b) Connect the other end of the power cable to a power source.
 - When connecting to an HVAC power source, insert the C14 or LS-25 plug in a receptacle for the HVAC power source.
 - When connecting to an HVDC power source, do the following:
 1. Verify that the power is turned off at a circuit breaker for the power source terminals.
 2. Remove the nuts from each of the terminal posts for the power supply.
 3. Place the power cable negative-wire terminal ring on the negative terminal for the power source and secure them with a terminal nut.
 4. Place the power cable positive-wire terminal ring on the positive terminal for the power source and secure them with a terminal nut.
 5. Place the power cable ground-wire terminal ring on the ground terminal for the power source and secure them with a terminal nut.
 6. If there is a safety cover for the power source terminals, place and secure it over the terminals to avoid an electrical shock hazard.
 7. Turn on the power at the power source circuit breaker.
- Step 3** For each DC power supply, do the following:
- a) Turn off the circuit breaker for the power source to avoid an electrical shock hazard.
 - b) Verify that the power cable wires from the power source are connected to a connector block.
 - c) Insert the connector block into the receptacle on the power supply. Make sure that the connector block clicks when fully inserted in the receptacle and does not pull out.
 - d) If there is a safety cover for the terminals, place and secure it over the terminals to avoid an electrical shock hazard.
 - e) Turn on the power at the circuit breaker for the DC power source.
- Step 4** Verify that the power supply LED is on and green.
- Step 5** Listen for the fans; they should begin operating when the power supply is powered.

Step 6 After the switch boots, verify that the following LEDs are lit:

- On the fan modules, the Status (STA or STS) LED is green.

If a fan module Status LED is not green, try reinstalling the fan module.

- After initialization, the switch chassis Status (labeled as STA or STS) LED is green.

Step 7 Verify that the system software has booted and the switch has initialized without error messages.

A setup utility automatically launches the first time that you access the switch and guides you through the basic configuration. For instructions on how to configure the switch and check module connectivity, see the appropriate Cisco Nexus 9000 Series configuration guide.



CHAPTER 4

Connecting the Switch to the Network

- [Overview of Network Connections, on page 33](#)
- [Connecting a Console to the Switch, on page 34](#)
- [Creating the Initial Switch Configuration, on page 35](#)
- [Setting Up the Management Interface, on page 36](#)
- [Connecting Interface Ports to Other Devices, on page 37](#)
- [Uplink Connections, on page 37](#)
- [Downlink Connections, on page 37](#)

Overview of Network Connections

After you install the switch in a rack and power it up, you are ready to make the following network connections:

- **Console connection**—This is a direct local management connection that you use to initially configure the switch. You must make this connection first to initially configure the switch and determine its IP address, which is needed for the other connections.
- **Management connection**—After you complete the initial configuration using a console, you can make this connection to manage all future switch configurations.
- **Uplink and downlink interface connections**—These are connections to hosts and servers in the network.

Each of these connection types is explained in one of the sections that follow.



Note When running cables in overhead or subfloor cable trays, we strongly recommend that you locate power cables and other potential noise sources as far away as practical from network cabling that terminates on Cisco equipment. In situations where long parallel cable runs cannot be separated by at least 3.3 feet (1 meter), we recommend that you shield any potential noise sources by housing them in a grounded metallic conduit.



Note When using SFP+ or SFP transceivers in a QSFP+ or QSFP28 uplink port, install a QSFP-to-SFP adapter, such as the CVR-QSFP-SFP10G adapter, in the QSFP port and then install the SFP+ or SFP transceiver. The switch automatically sets the port speed to the speed of the installed transceiver.

Connecting a Console to the Switch

Before you create a network management connection for the switch or connect the switch to the network, you must create a local management connection through a console terminal. And then configure an IP address for the switch. You can use the console to perform the following functions, each of which can be performed through the management interface after you make that connection:

- Configure the switch using the command-line interface (CLI).
- Monitor network statistics and errors.
- Configure Simple Network Management Protocol (SNMP) agent parameters.
- Download software updates.

You make this local management connection between the asynchronous serial port on a supervisor module and a console device capable of asynchronous transmission. Typically, you can use a computer terminal as the console device. On the supervisor modules, you use the console serial port.



Note Before you can connect the console port to a computer terminal, make sure that the computer terminal supports VT100 terminal emulation. The terminal emulation software makes communication between the switch and computer possible during setup and configuration.

Before you begin

- The switch must be fully installed in its rack, which is connected to a power source, and grounded.
- The necessary cabling for the console, management, and network connections must be available.
 - An RJ-45 rollover cable is provided in the switch accessory kit.
 - Network cabling is routed to the location of the installed switch.

Step 1 Configure the console device to match the following default port characteristics:

- 9600 baud
- 8 data bits
- 1 stop bit
- No parity

Step 2 Connect an RJ-45 rollover cable to the console port on the switch.

You can find this cable in the accessory kit.

Step 3 Route the RJ-45 rollover cable to the console or modem.

Step 4 Connect the other end of the RJ-45 rollover cable to the console or to a modem.

What to do next

You are ready to create the initial switch configuration (see [Creating the Initial Switch Configuration, on page 35](#)).

Creating the Initial Switch Configuration

You assign an IP address to the switch management interface so that you can then connect the switch to the network.

When you initially power up the switch, it boots up and asks you a series of questions to configure the switch. To connect the switch to the network, you can use the default choices for each configuration except the IP address, which you must provide. You can perform the other configurations later as described in the *Cisco Nexus 9000 Series NX-OS Fundamentals Configuration Guide*.



Note Know the unique name that is needed to identify the switch among the devices in the network.

Before you begin

- A console device must be connected with the switch.
- The switch must be connected to a power source.
- Determine the IP address and the netmask that is needed for the Management (Mgmt0) interface.

Step 1 Power up the switch by connecting each installed power supply to an AC circuit.

If you are using the combined or power-supply ($n+1$) power mode, connect all the power supplies to the same AC circuit. If you are using the input-source ($n+n$) power mode, connect half of the power supplies to one AC circuit. And connect the other half of the power supplies to another AC circuit.

The Input and Output LEDs on each power supply light up (green) when the power supply units are sending power to the switch, and the software asks you to specify a password to use with the switch.

Step 2 Enter a new password to use for this switch.

The software checks the security strength of your password and rejects your password if it is not considered to be a strong password. To increase the security strength of your password, make sure that it adheres to the following guidelines:

- At least eight characters
- Minimizes or avoids the use of consecutive characters (such as "abcd").
- Minimizes or avoids repeating characters (such as "aaabbb").
- Does not contain recognizable words from the dictionary.
- Does not contain proper names.
- Contains both uppercase and lowercase characters
- Contains numbers and letters

Examples of strong passwords include the following:

- If2CoM18
- 2004AsdfLkj30
- Cb1955S21

Note Clear text passwords cannot include the dollar sign (\$) special character.

Tip If a password is trivial (such as a short, easy-to-decipher password), the software will reject your password configuration. Be sure to configure a strong password as explained in this step. Passwords are case-sensitive.

If you enter a strong password, the software asks you to confirm the password.

Step 3 Enter the same password again.

If you enter the same password, the software accepts the password and begins asking a series of configuration questions.

Step 4 Until you are asked for an IP address, you can enter the default configuration for each question.

Repeat this step for each question until you are asked for the Mgmt0 IPv4 address.

Step 5 Enter the IP address for the management interface.

The software asks for the Mgmt0 IPv4 netmask.

Step 6 Enter a network mask for the management interface.

The software asks if you need to edit the configuration.

Step 7 Enter **no** not to edit the configuration.

The software asks if you need to save the configuration.

Step 8 Enter **yes** to save the configuration.

What to do next

You can now set up the management interface for each supervisor module on the switch.

Setting Up the Management Interface

The RJ-45 and/or SFP management ports provide out-of-band management, which enables you to use the command-line interface (CLI) to manage the switch by its IP address. You can use one of these ports depending on the cable and connectors that you are using to connect the management interface to the network.

Before you begin

- The switch must be powered on.
- The switch must be initially configured using a console.

-
- Step 1** Connect the management cable into the management port on the switch. For shorter connections, you can use a cable with RJ-45 connectors. For longer connections, you can use an optical cable with SFP transceivers (LH or SX type).
- Note** Use only one of these management ports—the switch does not support the use of both management ports.
- Step 2** Connect the other end of the cable to a 10/100/1000 or SFP port on a network device.
-

Connecting Interface Ports to Other Devices

After you perform the initial configuration for the switch and create a management connection, you are ready to connect the interface ports on the switch to other devices. Depending on the types of interface ports on the switch, you will need to use interface cables with QSFP28, QSFP+, SFP+, SFP transceivers, or RJ-45 connectors to connect the switch to other devices.



Note If you need to use SFP+ or SFP transceivers in a QSFP+ or QSFP28 uplink port, install a QSFP-to-SFP adapter, such as the CVR-QSFP-SFP10G adapter, in the QSFP port and then install the SFP+ or SFP transceiver. The switch automatically sets the port speed to the speed of the installed transceiver.

If the transceivers that you are using can be separated from their optical cables, install the transceivers without their cables before inserting the cables into the transceivers. This helps to prolong the life of both the transceiver and cables. When removing transceivers from the switch, it is best to remove the optical cable first and then remove the transceiver.

To determine which transceivers, adapters, and cables are supported by this switch, see the [Cisco Transceiver Modules Compatibility](#) Information document.

Uplink Connections

For a list of transceivers and cables used by this switch for uplink connections, see <http://www.cisco.com/c/en/us/support/interfaces-modules/transceiver-modules/products-device-support-tables-list.html>.

The six uplink ports support 40- and 100-Gigabit Ethernet using QSFP28 transceivers.



Warning **Statement 1051**—Laser Radiation

Invisible laser radiation may be emitted from disconnected fibers or connectors. Do not stare into beams or view directly with optical instruments.

Downlink Connections

The Cisco Nexus 93180YC-FX switch has 48 downlink ports that connect to servers. Each of these ports supports 1-, 10-, and 25-Gigabit speeds over optical cables.

For a listing of the transceivers and cables that the optical downlink ports support, see <http://www.cisco.com/c/en/us/support/interfaces-modules/transceiver-modules/products-device-support-tables-list.html>



CHAPTER 5

Replacing Components

- [Replacing a Fan Module, on page 39](#)
- [Replacing a Power Supply Module, on page 40](#)

Replacing a Fan Module

You can replace a fan module while the switch is operating so long as you perform the replacement within one minute. If you cannot perform the replacement within one minute, leave the original fan module in the chassis to maintain the designed airflow until you have the replacement fan module on hand and can perform the replacement.



Caution If you are replacing a module during operations, be sure that the replacement fan module has the correct direction of airflow, which means that it has the same airflow direction as the other modules in the chassis. Also, be sure that the airflow direction takes in air from a cold aisle and exhausts to a hot aisle. Otherwise, the switch can overheat and shutdown.

If you are changing the airflow direction of all the modules in the chassis, you must shutdown the switch before replacing all the fan and power supply modules with modules using the other airflow direction. During operations, all of the modules must have the same direction of airflow.

Removing a Fan Module



Caution The fans might still be turning when you remove the fan assembly from the chassis. Keep fingers, screwdrivers, and other objects away from the openings in the fan assembly's housing.

-
- Step 1** On the fan module that you are removing, press the two sides of the fan module handle next to where it connects to the fan module and pull on the handles enough to unseat it from its connectors.
- Step 2** Holding the handle, pull the module out of the chassis.

Caution Do not touch the electrical connectors on the back side of the module and prevent anything else from coming into contact with and damaging the connectors.

Installing a Fan Module

Before you begin

- A fan slot must be open and ready for the new fan module to be installed.
 - You must have a new fan module on hand and ready to install within one minute of removing the original fan module if the switch is operating.
 - The new fan module must have the same airflow direction as the other fan and power supply modules installed in the switch.
-

- Step 1** Holding the fan module by its handle, align the back of the fan module (the side with the electrical connectors) to the open fan slot in the chassis.
- Step 2** Slide the fan module into the slot until it clicks in place.
- Step 3** Verify that the Status (STS) LED turns on and becomes green.
-

Replacing a Power Supply Module

The switch requires two power supplies for redundancy. With one power supply providing the necessary power for operations, you can replace the other power supply during operations so long as the new power supply has the same airflow direction as the other modules in the chassis.

You can replace a power supply with another supported power supply that has the same power source type as the other installed power supply. Additionally, the airflow direction of the power supply must match or conform to the airflow direction of the installed fan modules. For the airflow direction used by the switch, see the coloring of the fan modules.

Replacing an AC Power Supply

You can replace an AC power supply during operations so long as the other power supply provides to the switch.

Before you begin



Note You can determine the airflow direction by looking at the coloring of the latch on each power supply. AC power supplies with burgundy latches have port-side intake airflow direction, and power supplies with blue latches have port-side exhaust airflow direction.

- The replacement power supply must have the same wattage and airflow direction as the power supply being replaced. Do not mix AC, DC, HVAC/HVDC power supplies in the same switch.
- An AC power source must be within reach of the power cable that will be used with the replacement power supply. If you are using $n+n$ power redundancy, there must be a separate power source for each power supply installed in the chassis.
- There must be an earth ground connection to the chassis that you are installing the replacement module. AC power supplies connected to AC power sources are automatically grounded through their power cable.

Step 1 Remove an AC power supply as follows:

- a) Holding the plug for the power cable, pull the plug out from the power receptacle on the power supply and verify that both power supply LEDs are off.
- b) Grasp the power supply handle while pressing the colored release latch towards the power supply handle.
- c) Place your other hand under the power supply to support it while you slide it out of the chassis.

Caution Do not touch the electrical connections on the back side of the module and prevent anything else from coming into contact with and damaging the connectors.

Step 2 Install the replacement power supply as follows:

- a) Holding the replacement power supply with one hand underneath the module and the other hand holding the handle, turn the power supply so that its release latch is on the right side and align the back end of the power supply (the end with the electrical connections) to the open power supply slot before carefully sliding the power supply all the way into the slot until it clicks into place.

Note If the power supply does not fit into the open slot, turn the module over before sliding it carefully into the open slot.

- b) Test the installation by trying to pull the power supply out of the slot without using the release latch.

If the power supply does not move out of place, it is secured in the slot. If the power supply moves, carefully press it all the way into the slot until it clicks in place.

- c) Attach the power cable to the electrical outlet on the front of the power supply.
- d) Make sure that the other end of the power cable is attached to the appropriate power source for the power supply.

Note Depending on the outlet receptacle on your power distribution unit, you might need the optional jumper cable to connect the switch to your outlet receptacle.

- e) Verify that the power supply is operational by making sure that the power supply LED is green.

Replacing a High Voltage (HVAC/HVDC) Power Supply

You can replace an HVACHVDC power supply during operations so long as the other power supply provides power to the switch.

Before you begin

- The replacement power supply must have the same wattage and airflow direction as the power supply being replaced. Do not mix AC, DC, HVAC/HVDC power supplies in the same switch.



Note You can determine the airflow direction by looking at the coloring of the latch on each power supply. HVAC/HVDC power supplies have white latches, which indicate that they have dual airflow directional capability. Those power supplies automatically use the same airflow direction as the fan modules installed in the same switch.

- An HVAC/HVDC power source must be within reach of the power cable that will be used with the replacement power supply. If you are using $n+n$ power redundancy, there must be a separate power source for each power supply installed in the chassis.
 - There must be an earth ground connection to the chassis in which you are installing the replacement power supply. HVAC/HVDC power supplies connected to AC power sources are automatically grounded by their power cable when connected to the power supply and AC power source. HVAC/HVDC power supplies connected to DC power sources have Saf-D-Grid power cables with three connectors on the power source end--you connect one of those connectors to the earth ground.
-

Step 1 Remove an HVAC/HVDC power supply as follows:

- Turn off the circuit breaker for the power feed to the power supply that you are replacing.
Be sure that the LEDs turn off on the power supply that you are removing.
- Remove the power cable from the power supply by pressing the tab on the top of the Anderson Power SAF-D-Grid connector and pull the cable and connector out of the power supply.
- Grasp the power supply handle while pressing the colored release latch towards the power supply handle.
- Place your other hand under the power supply to support it while you slide it out of the chassis.

Caution Do not touch the electrical connections on the back side of the module and prevent anything else from coming into contact with and damaging the connectors.

Step 2 Install the replacement power supply as follows:

- Holding the replacement power supply with one hand underneath the module and the other hand holding the handle, turn the power supply so that its release latch is on the right side and align the back end of the power supply (the end with the electrical connections) to the open power supply slot before carefully sliding the power supply all the way into the slot until it clicks into place.

Note If the power supply does not fit into the open slot, turn the module over before sliding it carefully into the open slot.

- Test the installation by trying to pull the power supply out of the slot without using the release latch.
If the power supply does not move out of place, it is secured in the slot. If the power supply moves, carefully press it all the way into the slot until it clicks in place.
- Attach the Saf-D-Grid end of the power cable to the electrical outlet on the front of the power supply.
- Make sure that the other end of the power cable is attached to the appropriate power source for the power supply.

- For an HVAC power source, plug the other end of the power cable into the power source.
 - For a HVDC power source, verify that the circuit breaker is turned off and then connect each of the three cable connectors to the appropriate DC and grounding terminals on the power source. If there is a cover plate for the DC terminals, install the plate to prevent accidental contact with the terminals.
- e) If using an HVDC power source, turn on the circuit breaker for the power source.
- f) Verify that the power supply is operational by making sure that the power supply LED is green.

Replacing a DC Power Supply

You can replace an DC power supply during operations so long as the other power supply provides power to the switch.

Before you begin

- The replacement power supply must have the same wattage and airflow direction as the power supply being replaced. Do not mix AC, DC, HVAC/HVDC power supplies in the same switch.



Note You can determine the airflow direction by looking at the coloring of the latch on each power supply. AC power supplies with burgundy latches have port-side intake airflow direction, and power supplies with blue latches have port-side exhaust airflow direction.

- An DC power source must be within reach of the power cables that will be used with the replacement power supply. If you are using $n+n$ power redundancy, there must be a separate power source for each power supply installed in the chassis.
- There must be an earth ground connection to the chassis in which you are installing the replacement power supply. If the switch is mounted properly in a grounded rack then there is no need to ground the PSU. Some DC power supplies connected to DC power sources have three power cables (two for DC power and one for grounding). Some, like the (NXA-PDC-1100W) only have two power cables (both for DC power).
- We recommend 8-AWG wire for DC installation in the U.S.
- All DC power supplies have reverse polarity protection. When you inadvertently connect the input power (+) to the DC PSU's – terminal and the input power – to the DC PSU's (+) terminal, the PSU will not be damaged and will operate fine after the input power feeds are correctly wired.

Step 1 Remove a DC power supply as follows:

- a) Turn off the circuit breaker for the power feed to the power supply that you are replacing.
- Be sure that the LEDs turn off on the power supply that you are removing.
- b) Remove the DC power connector block from the power supply by doing the following:
1. Push the orange plastic button on the top of the connector block inward toward the power supply.

2. Pull the connector block out of the power supply.
- c) Grasp the power supply handle while pressing the release latch towards the power supply handle.
 - d) Place your other hand under the power supply to support it while you slide it out of the chassis.

Caution Do not touch the electrical connections on the back side of the module and prevent anything else from coming into contact with and damaging the connectors.

Step 2 Install the replacement power supply as follows:

- a) Holding the replacement power supply with one hand underneath the module and the other hand holding the handle, turn the power supply so that its release latch is on the right side and align the back end of the power supply (the end with the electrical connections) to the open power supply slot before carefully sliding the power supply all the way into the slot until it clicks into place.

Note If the power supply does not fit into the open slot, turn the module over before sliding it carefully into the open slot.

- b) Test the installation by trying to pull the power supply out of the slot without using the release latch.
If the power supply does not move out of place, it is secured in the slot. If the power supply moves, carefully press it all the way into the slot until it clicks in place.
 - c) Attach the power connector block end of the power cable to the electrical outlet on the front of the power supply.
 - d) Turn on the circuit breaker for the power source.
 - e) Verify that the power supply is operational by making sure that the power supply LED is green.
-



APPENDIX **A**

Rack Specifications

- [Overview of Racks, on page 45](#)
- [General Requirements for Cabinets and Racks, on page 45](#)
- [Requirements Specific to Standard Open Racks, on page 46](#)
- [Requirements Specific to Perforated Cabinets, on page 46](#)
- [Cable Management Guidelines, on page 47](#)

Overview of Racks

You can install the switch in the following types of cabinets and racks, assuming an external ambient air temperature range of 0 to 104°F (0 to 40°C):

- Standard perforated cabinets
- Solid-walled cabinets with a roof fan tray (bottom to top cooling)
- Standard open racks



Note If you are selecting an enclosed cabinet, we recommend one of the thermally validated types, either standard perforated or solid-walled with a fan tray.



Note We do not recommend that you use racks that have obstructions (such as power strips), because the obstructions could impair access to field-replaceable units (FRUs).

General Requirements for Cabinets and Racks

The cabinet or rack must also meet the following requirements:

- Standard 19-inch (48.3 cm) (two- or four-post EIA cabinet or rack, with mounting rails that conform to English universal hole spacing per section 1 of ANSI/EIA-310-D-1992). For more information, see [Requirements Specific to Perforated Cabinets, on page 46](#).

- The minimum vertical rack space requirement per chassis is:
 - For a one RU (rack unit) switch, 1.75 inches (4.4 cm)
 - For a one and a half RU (rack unit) switch, 2.63 (6.68 cm)
 - For a two RU (rack unit) switch, 3.5 inches (8.8 cm)
 - For a three RU (rack unit) switch, 5.25 inches (13.3 cm)
- The width between the rack-mounting rails must be at least 17.75 inches (45.0 cm) if the rear of the device is not attached to the rack. For four-post EIA racks, this measurement is the distance between the two front rails.

Four-post EIA cabinets (perforated or solid-walled) must meet the following requirements:

- The minimum spacing for the bend radius for fiber-optic cables should have the front-mounting rails of the cabinet offset from the front door by a minimum of 3 inches (7.6 cm).
- The distance between the outside face of the front mounting rail and the outside face of the back mounting rail should be 23.0 to 30.0 inches (58.4 to 76.2 cm) to allow for rear-bracket installation.

For the specific rack dimension information for each possible rack-mount, see [Installation Options with Rack-Mount Kits](#), on page 16.

Requirements Specific to Standard Open Racks

If you are mounting the chassis in an open rack (no side panels or doors), ensure that the rack meets the following requirements:

- The minimum vertical rack space per chassis must be equal to the rack unit (RU) of the chassis. One rack unit is equal to 1.75 inches (4.4 cm).
- The distance between the chassis air vents and any walls should be 2.5 inches (6.4 cm).

Requirements Specific to Perforated Cabinets

A perforated cabinet has perforations in its front and rear doors and side walls. Perforated cabinets must meet the following requirements:

- The front and rear doors must have at least a 60 percent open area perforation pattern, with at least 15 square inches (96.8 square cm) of open area per rack unit of door height.
- The roof should be perforated with at least a 20 percent open area.
- The cabinet floor should be open or perforated to enhance cooling.

The Cisco R Series rack conforms to these requirements.

Cable Management Guidelines

To help with cable management, you might want to allow additional space in the rack above and below the chassis to make it easier to route all of the fiber optic or copper cables through the rack.



APPENDIX **B**

System Specifications

- [Environmental Specifications, on page 49](#)
- [Switch Dimensions, on page 49](#)
- [Switch and Module Weights and Quantities, on page 50](#)
- [Transceiver and Cable Specifications, on page 50](#)
- [Switch Power Input Requirements, on page 50](#)
- [Power Specifications, on page 51](#)
- [Power Cable Specifications, on page 53](#)
- [Regulatory Standards Compliance Specifications, on page 55](#)

Environmental Specifications

Environment		Specification
Temperature	Ambient operating temperature	32 to 104°F (0 to 40°C)
	Ambient nonoperating	−40 to 158°F (−40 to 70°C)
Relative humidity	Nonoperating	5 to 95%
	Operating	5 to 90%
Altitude	Operating	0 to 13,123 feet (0 to 4,000 meters)

Switch Dimensions

Switch	Width	Depth	Height
Cisco Nexus 93180YC-FX	17.3 inches (43.9 cm)	22.5 inches (57.1 cm)	1.72 inches (4.4 cm) (1 RU)

Switch and Module Weights and Quantities

Component	Weight per Unit	Quantity
Cisco Nexus 93180YC-FX Chassis (N9K-C93180YC-FX)	17.4 lb (7.9 kg)	1
Fan Module	—	4
– Port-side exhaust (blue) (NXA-FAN-30CFM-F)	0.26 lb (0.12 kg)	
– Port-side intake (burgundy) (NXA-FAN-30CFM-B)		
Power Supplies	—	2 (1 for operations and 1 for redundancy)
– 500-W AC port-side exhaust (blue) (NXA-PAC-500W-PE)	2.42 lb (1.1 kg)	
– 500-W AC port-side intake (burgundy) (NXA-PAC-500W-PI)	2.42 lb (1.1 kg)	
– 1200-W HVAC/HVDC dual-direction (white) (N9K-PUV-1200W)	2.42 lb (1.1 kg)	
– 930-W DC port-side exhaust (blue) (NXA-PDC-930W-PE)	2.42 lb (1.1 kg)	
– 930-W DC port-side intake (burgundy) (NXA-PDC-930W-PI)	2.42 lb (1.1 kg)	

Transceiver and Cable Specifications

To determine which transceivers, adapters, and cables are supported by this switch, see <https://www.cisco.com/c/en/us/support/interfaces-modules/transceiver-modules/products-device-support-tables-list.html>.

To see the transceiver specifications and installation information, see <https://www.cisco.com/c/en/us/support/interfaces-modules/transceiver-modules/products-device-support-tables-list.html>.

Switch Power Input Requirements

The following table lists the typical amount of power that the switch consumes. It also lists the maximum amount of power that you must provision for the switch and power supply for peak conditions.



Note Some power supplies have capabilities that are greater than the maximum power requirements for a switch. To determine the power consumption characteristics for the switch, use the typical and maximum requirements that are listed in the following table.

Switch	Typical Power Consumption (AC or DC)	Maximum Power Consumption (AC or DC)	Heat Dissipation Requirement
Cisco Nexus 93180YC-FX	260 W	425 W	1450.16 BTU per hour

Power Specifications

Power specifications include the specifications for each type of power supply module.

500-W AC Power Supply Specifications

These specifications apply to the following power supplies:

- NXA-PAC-500W-PE
- NXA-PAC-500W-PI

Characteristic	Specification
AC input voltage	Nominal range: 100 and 240 VAC (Range: 90-132 VAC, 180-264 VAC)
AC input frequency	Nominal range: 50 to 60 Hz (Range: 47-63 Hz)
Maximum AC input current	7.6 A at 100 VAC 3.65 A at 208 VAC
Maximum input volt-amperes	760 A at 100 VAC
Maximum output power per power supply	500 W
Maximum inrush current	33 A (sub-cycle duration)
Maximum hold-up time	12 ms at 500 W
Power supply output voltage	12 VDC
Power supply standby voltage	12 VDC
Efficiency rating	Climate Savers Platinum Efficiency (80Plus Platinum certified)
Form factor	RSP1

1200-W HVAC/HVDC Power Supply Specifications

These specifications apply to the 1200-W HVAC/HVDC (N9K-PUV-1200W) power supplies.

Characteristic	Specification
Input voltage <ul style="list-style-type: none"> • AC (for 1230 W output) • DC (for 1230 W output) 	Nominal (Range) <ul style="list-style-type: none"> • 200 to 277 VAC
AC input frequency	Nominal: 50 to 60 Hz (Range: 47-63 Hz)

Characteristic	Specification
Maximum AC input current	100 VAC, 10A
Maximum inrush current	35 A (cold turn on); 70 A (hot turn on)
Maximum output Watts <ul style="list-style-type: none"> • For 200 to 277 VAC • For 192 to 400 VDC 	Per power supply <ul style="list-style-type: none"> • 1230 W • 1230 W
Power supply output voltage <ul style="list-style-type: none"> • For 200 to 277 VAC • For 192 to 400 VDC 	Per power supply <ul style="list-style-type: none"> • 12 VDC at 100 A • 12 VDC at 100 A
Power supply standby voltage	12 V at 2.5 A
Efficiency rating	Climate Savers Platinum Efficiency (80Plus Platinum certified)
Form factor	RSP1

930-W DC Power Supply Specifications

These specifications apply to the following power supplies:

- NXA-PDC-930W-PE
- NXA-PDC-930W-PI

Characteristic	Specification
DC input voltage range	Nominal range: -48 to -60 VDC nominal (Range: -40 to -60 VDC)
Maximum DC input current	23 A at -48 VDC
Maximum output power per power supply	930 W
Maximum inrush current	35 A (sub-cycle duration)
Maximum hold-up time	8 ms at 930 W
Power supply output voltage	12 VDC
Power supply standby voltage	12 VDC
Efficiency rating	Greater than 92% at 50% load
Form factor	RSP1

Power Cable Specifications

The following sections specify the power cables that you can order and use with this switch.

Power Cable Specifications for AC Power Supplies

Power Type	Power Cord Part Number	Cord Set Description
	CAB-C13-C14-2M	Power Cord Jumper, C13-C14 Connectors, 6.6 feet (2.0 m)
	CAB-C13-CBN	Cabinet jumper power cord, 250 VAC, 10 A, C14-C13 connectors, 2.3 feet (0.7 m)
Argentina	CAB-250V-10A-AR	250 V, 10 A, 8.2 feet (2.5 m)
Australia	CAB-9K10A-AU	250 VAC, 10 A, 3112 plug, 8.2 feet (2.5 m)
Brazil	CAB-250V-10A-BR	250 V, 10 A, 6.9 feet (2.1 m)
European Union	CAB-9K10A-EU	250 VAC, 10 A, CEE 7/7 plug, 8.2 feet (2.5 m)
India	CAB-IND-10A	10 A, 8.2 feet (2.5 m)
India	CAB-C13-C14-2M-IN	Power Cord Jumper, C13-C14 Connectors, 6.6 feet (2.0 m)
India	CAB-C13-C14-3M-IN	Power Cord Jumper, C13-C14 Connectors, 9.8 feet (3.0 m)
Israel	CAB-250V-10A-IS	250 V, 10 A, 8.2 feet (2.5 m)
Italy	CAB-9K10A-IT	250 VAC, 10 A, CEI 23-16/VII plug, 8.2 feet (2.5 m)
Japan	CAB-C13-C14-2M-JP	Power Cord Jumper, C13-C14 Connectors, 6.6 feet (2.0 m)
North America	CAB-9K12A-NA	125 VAC, 13 A, NEMA 5-15 plug, 8.2 feet (2.5 m)
North America	CAB-AC-L620-C13	NEMA L6-20-C13, 6.6 feet (2.0 m)
North America	CAB-N5K6A-NA	200/240V, 6A, 8.2 feet (2.5 m)
Peoples Republic of China	CAB-250V-10A-CN	250 V, 10 A, 8.2 feet (2.5 m)
South Africa	CAB-250V-10A-ID	250 V, 10 A, 8.2 feet (2.5 m)
Switzerland	CAB-9K10A-SW	250 VAC, 10 A, MP232 plug, 8.2 feet (2.5 m)
United Kingdom	CAB-9K10A-UK	250 VAC, 10 A, BS1363 plug (13 A fuse), 8.2 (2.5 m)

Power Type	Power Cord Part Number	Cord Set Description
All except Argentina, Brazil, and Japan	NO-POWER-CORD	No power cord included with switch

HVAC/HVDC Power Cables Supported by ACI-Mode and NX-OS Mode Switches

Part Number	Cord Set Description	Photo
CAB-HVAC-SD-0.6M	HVAC 2-foot (0.6 m) cable with Saf-D-Grid and SD connectors 277V AC	
CAB-HVAC-C14-2M	HVAC 6.6-foot (2.0 m) cable with Saf-D-Grid and C14 (use for up to 240 V) connector 250V AC	
CAB-HVAC-RT-0.6M	HVAC 2-foot (0.6 m) cable with Saf-D-Grid and RT connector 277V AC	
CAB-HVDC-3T-2M	HVDC 6.6-foot (2.0 m) cable with Saf-D-Grid and three terminal connectors 300V AC / 400V DC (+200/-200 V DC)	
NO-POWER-CORD	All except Argentina, Brazil, and Japan No power cord included with switch	Not applicable

Table 3: HVAC/HVDC Power Cables Callout Table

1	Connect this end to the power supply unit.
---	--

DC Power Cable Specifications

Part Number	Description	Photo
NXA-PDC-930W-PE/PI	The 930W DC power supply (NXA-PDC-930W-PE/PI) is shipped with cable CAB-48DC-40A-8AWG.	

Regulatory Standards Compliance Specifications

The following table lists the regulatory standards compliance for the switch.

Table 4: Regulatory Standards Compliance: Safety and EMC

Specification	Description
Regulatory compliance	Products should comply with CE Markings according to directives 2004/108/EC and 2006/95/EC.
Safety	<ul style="list-style-type: none"> • CAN/CSA-C22.2 No. 60950-1 Second Edition • EN 60950-1 Second Edition • IEC 60950-1 Second Edition • IEC 623681 • AS/NZS 60950-1 • GB4943

Specification	Description
EMC: Emissions	<ul style="list-style-type: none">• 47CFR Part 15 (CFR 47) Class A• AS/NZS CISPR22 Class A• CISPR22 Class A• EN55022 Class A• ICES003 Class A• VCCI Class A• EN61000-3-2• EN61000-3-3• KN22 Class A• CNS13438 Class A
EMC: Immunity	<ul style="list-style-type: none">• EN55024• CISPR24• EN300386• KN 61000-4 series
RoHS	The product is RoH-6 compliant with exceptions for leaded-ball grid-array (BGA) balls and lead press-fit connectors.



APPENDIX C

LEDs

- [Switch Chassis LEDs, on page 57](#)
- [Fan Module LEDs, on page 57](#)
- [Power Supply LEDs, on page 57](#)

Switch Chassis LEDs

The BCN, STS, and ENV, LEDs are located on the left side of the front of the switch. The port LEDs appear as triangles pointing up or down to the nearest port.

Fan Module LEDs

The fan module LED is located below the air holes on the front of the module.

LED	Color	Status
STS	Green	The fan module is operational.
	Red	The fan module is not operational (fan is probably not functional).
	Off	Fan module is not receiving power.

Power Supply LEDs

The power supply LEDs are located on the left front portion of the power supply. Combinations of states that are indicated by the Okay (PS_OK) and Okay (AC_OK) LEDs indicate the status for the module as shown in the following table.

PS_OK LED	AC_OK LED	Status
Green	Green	Power supply is on and outputting power to the switch.
Flashing green	Off	Power supply is connected to a power source but not outputting power to the switch.

PS_OK LED	AC_OK LED	Status
Green	Flashing amber	Power supply warning—possibly one of the following conditions: <ul style="list-style-type: none"> • High voltage • High power • Low voltage • Slow power supply fan
Green	Amber	Rotor fault Note This behavior occurs if the fan rotor is stopped during normal switch operation.
Off	Off	AC cord that is removed while in redundant mode (while other PSU is running).



APPENDIX **D**

Additional Kits

- [Rack Mount Kit NXK-ACC-KIT-1RU](#), on page 59
- [Rack Mount Kit N3K-C3064-ACC-KIT](#), on page 60
- [Airflow Sleeve](#), on page 60

Rack Mount Kit NXK-ACC-KIT-1RU

The following table lists and illustrates the contents for the 1-RU rack-mount kit (NXK-ACC-KIT-1RU).

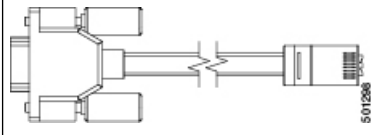
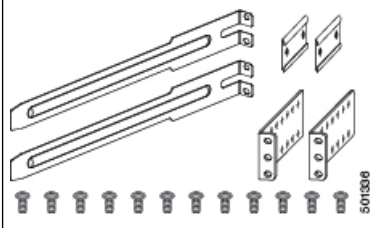

Illustration	Description	Quantity
	Rack-mount kit <ul style="list-style-type: none"> • Front brackets (2) • Rear brackets (2) • Slider rails (2) • M4 Phillips pan-head screws (10) 	1
	Ground lug kit <ul style="list-style-type: none"> • Two-hole lug (1) • M4 x 8-mm Phillips pan-head screws (2) 	1
Not applicable	EAC Compliance document	1
Not applicable	Hazardous substances list for customers in China	1

The following table lists and illustrates the console cable (CAB-CONSOLE-RJ45) that can be ordered.

Illustration	Description	Quantity
	Console cable with DB-9F and RJ-45F connectors	1

Rack Mount Kit N3K-C3064-ACC-KIT

The following table lists and illustrates the contents for the 1-RU rack-mount kit (N3K-C3064-ACC-KIT).

Illustration	Description	Quantity
	Rack-mount kit <ul style="list-style-type: none"> • Front-mount angled bracket (2) • Rear-mount slider bracket (2) • Slider rails (2) • M4 x 7 mm mounting screws (16) 	1
	Ground lug kit <ul style="list-style-type: none"> • Two-hole lug (1) • M4 x 8-mm Phillips pan-head screws (2) 	1
Not applicable	EAC Compliance document	1
Not applicable	Hazardous substances list for customers in China	1

The following table lists and illustrates the console cable (CAB-CONSOLE-RJ45) that can be ordered.

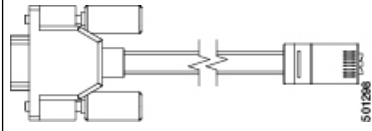
Illustration	Description	Quantity
	Console cable with DB-9F and RJ-45F connectors	1

Airflow Sleeve

The following table lists and illustrates the airflow sleeve (N9K-AIRFLOW-SLV).

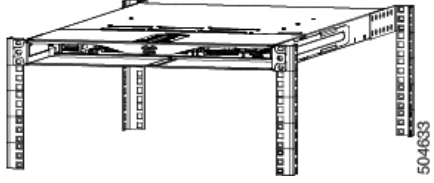
Illustration	Description	Quantity
 <p>504633</p>	Airflow sleeve	1



APPENDIX **E**

Site Preparation and Maintenance Records

- [Site Preparation Checklist, on page 63](#)
- [Contact and Site Information, on page 64](#)
- [Chassis and Module Information, on page 65](#)

Site Preparation Checklist

Planning the location and layout of your equipment rack or cabinet is essential for successful switch operation, ventilation, and accessibility.

The following table lists the site planning tasks that we recommend that you complete before you install the switch. Your completion of each task ensures a successful switch installation.

Planning Activity	Verification Time and Date
Space evaluation:	
Space and layout	
Floor covering	
Impact and vibration	
Lighting	
Physical access	
Maintenance access	
Environmental evaluation:	
Ambient temperature	
Humidity	
Altitude	
Atmospheric contamination	
Airflow	

Planning Activity	Verification Time and Date
Power evaluation:	
Input power type	
Power receptacles	
Receptacle proximity to the equipment	
Dedicated (separate) circuits for power redundancy	
UPS for power failures	
Grounding: proper wire gauge and lugs	
Circuit breaker size	
Grounding evaluation:	
Data center ground	
Cable and interface equipment evaluation:	
Cable type	
Connector type	
Cable distance limitations	
Interface equipment (transceivers)	
EMI evaluation:	
Distance limitations for signaling	
Site wiring	
RFI levels	

Contact and Site Information

Use the following worksheet to record contact and site information for the installation.

Contact person	
Contact phone	

Contact e-mail	
Building/site name	
Data center location	
Floor location	
Address (line 1)	
Address (line 2)	
City	
State/Provence	
Contact person	
ZIP/postal code	
Country	

Chassis and Module Information

Use the following worksheet to record information about the switch.

Contract number	
Chassis serial number	
Product number	

Use the following worksheet to record network-related information.

Switch IP address	
Switch IP netmask	
Hostname	
Domain name	
IP broadcast address	
Gateway/router address	
DNS address	

Use the following worksheet to record information about the modules in the switch.

Module Slot	Module Type	Module Serial Number	Notes
Fan module 1			

Module Slot	Module Type	Module Serial Number	Notes
Fan module 2			
Fan module 3			
Fan module 4			
Power Supply 1			
Power Supply 2			